

11V-13
180799

NASA
Technical
Memorandum

Space Station Redesign Option A

Modular Buildup Concept

NASA TM-108415

N94-10808

Unclass

G3/18 0180799

(NASA-TM-108415) SPACE STATION
REDESIGN OPTION A: MODULAR BUILDUP
CONCEPT (NASA) 85 p

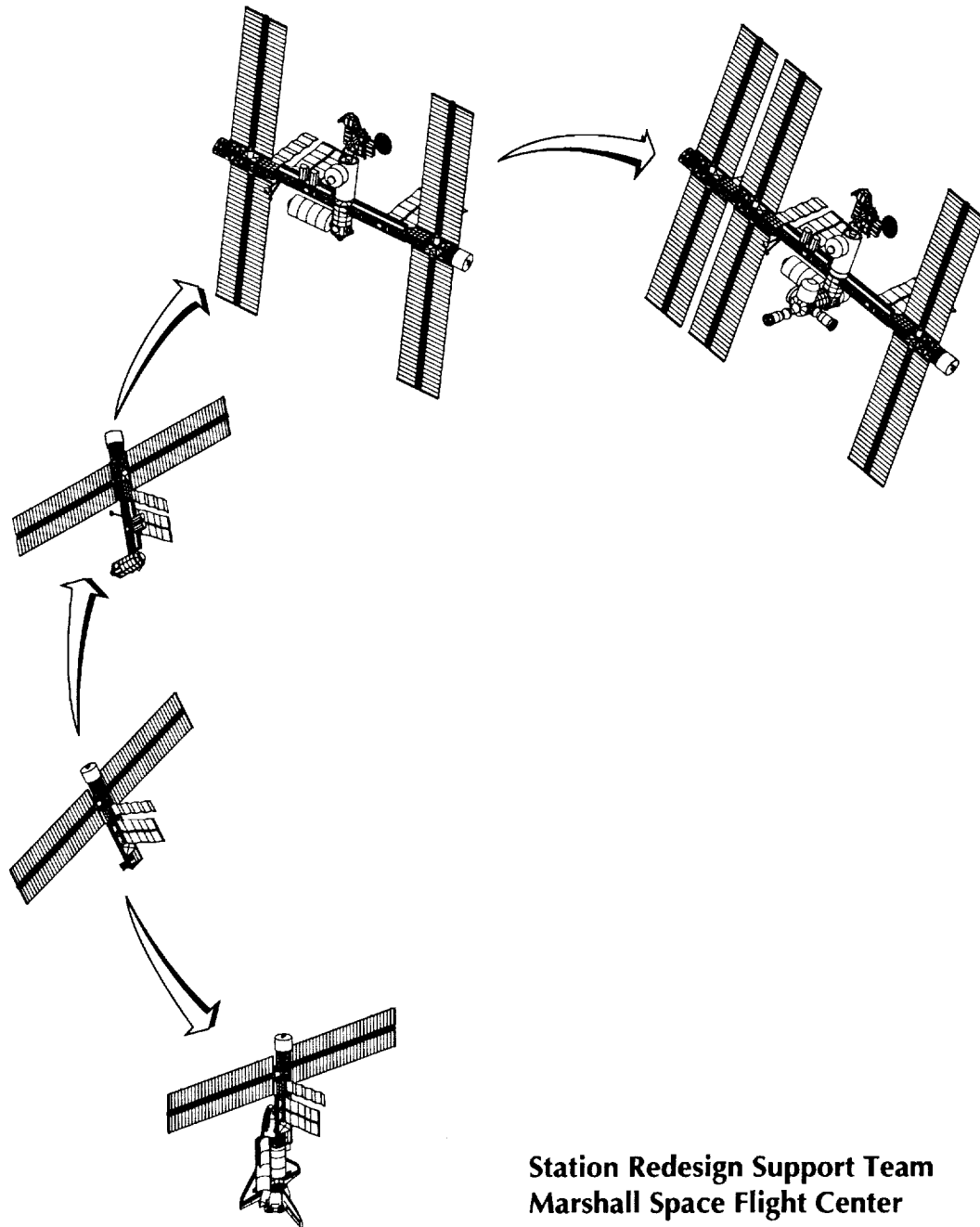

Station Redesign Support Team
Marshall Space Flight Center

June 10, 1993

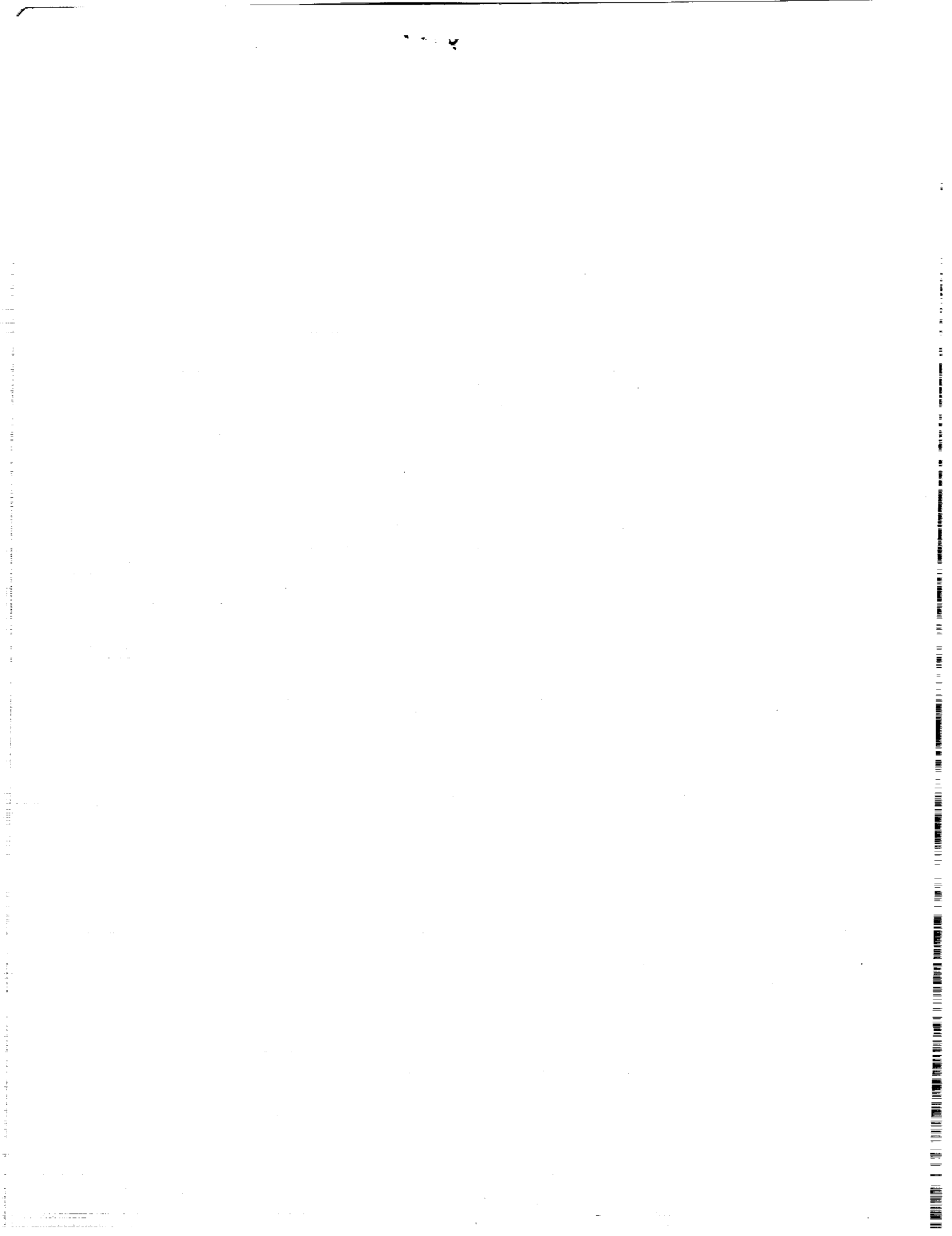

Space Station Redesign Option A Modular Buildup Concept

By

**The Space Station
Redesign Support Team
Marshall Space Flight Center**

June 10, 1993

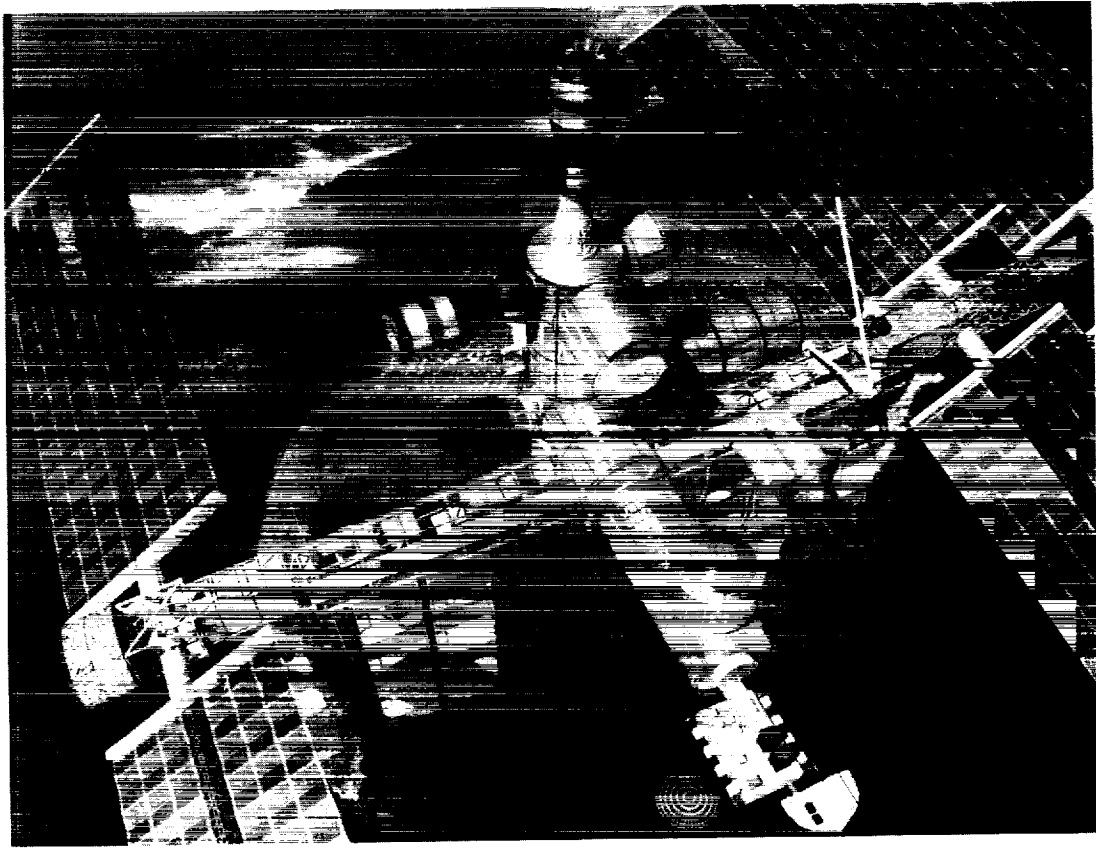

Space Station Option A-1.

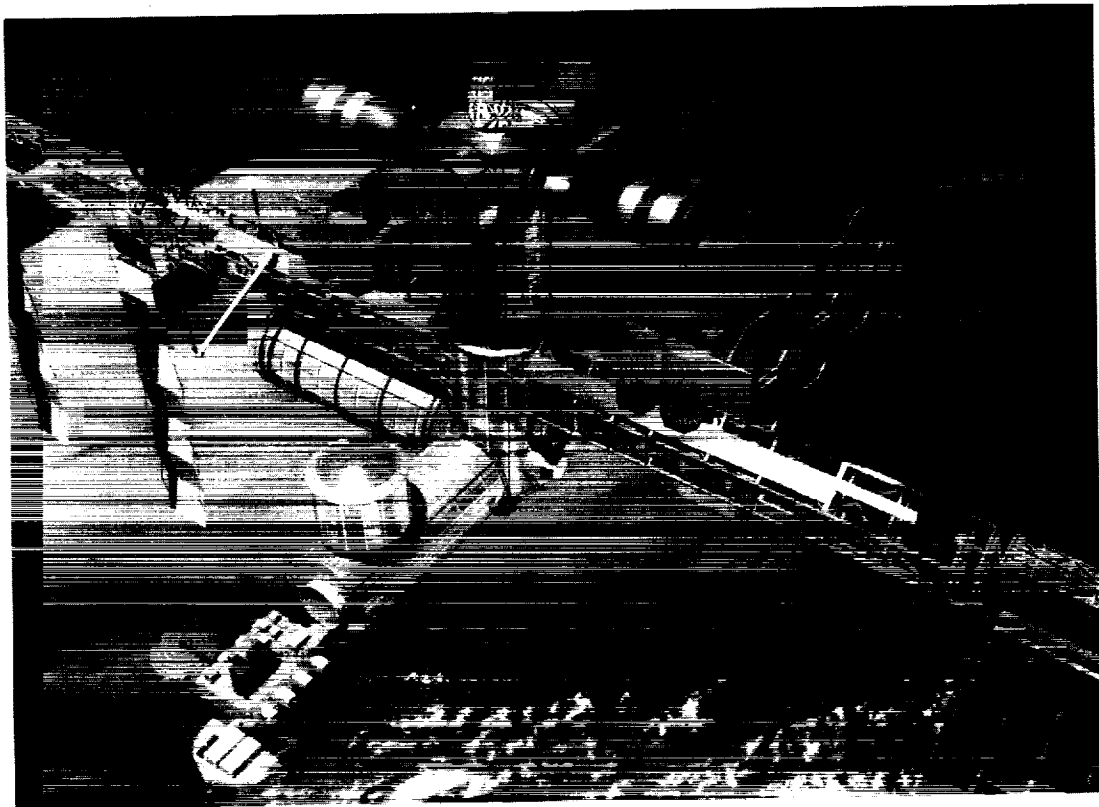

Space Station Option A-2.

Option A Space Station Study

Preface: Study Background and Approach

On March 9, 1993, President Clinton mandated that the National Aeronautics and Space Administration (NASA) look at lower-cost alternatives to the Space Station *Freedom* design. On March 25, 1993, President Clinton also established an Advisory Committee for the Redesign of the Space Station—the Blue Ribbon Panel (Appendix A, Figure A-1)—headed by Dr. Charles M. Vest, president of the Massachusetts Institute of Technology, to review NASA's work and to evaluate the NASA alternatives.

In response to the President's direction, the NASA Administrator, Mr. Daniel S. Goldin, established a Station Redesign Team (SRT) (Appendix A, Figures A-2 and A-3), appointing Dr. Joseph F. Shea as its head. Dr. Shea later resigned after an extended illness, and his deputy, Mr. Bryan O'Connor, took over that function. The team began operating in late March from its headquarters in Crystal City, Virginia. Three intercenter support teams—one each at Marshall Space Flight Center (MSFC), Johnson Space Center (JSC), and Langley Research Center (LaRC)—provided engineering and other support to the redesign team at Crystal City. The results of the redesign effort are documented in the *Space Station Redesign Team Final Report to the Advisory Committee on the Redesign of the Space Station*, June 1993.

The team at MSFC formulated and assessed a modular space station, "Option A," that could be significantly lower in cost than the current *Freedom* station design, but which could also grow to reach a capability nearly as great. The team at LaRC established and appraised a modular station, "Option B," similar to *Freedom*, but somewhat downsized in cost. The team at JSC defined and assessed a single-module station, "Option C," using a single, large-diameter pressurized structure, which could also be significantly cheaper than the *Freedom* approach. Thus, Option B was intended to be the concept most nearly like *Freedom*; Option A to be similar in approach to *Freedom*, but to span a spectrum from an austere capability to a near-*Freedom* capability; and Option C was intended to be the most radical departure from *Freedom*, having considerable differences from it in many aspects. Cost targets given near the outset were \$5 billion, \$7 billion, and \$9 billion for Options A, C, and B, respectively, although each option has growth steps that span a cost range beyond these targets. Capabilities of all options, of course, are reduced from those provided by *Freedom*.

This report summarizes the results of the study done by the support team at MSFC as of June 10. The level of detail is consistent with the short study time (approximately 2 months). The maturity of *Freedom* designs used intact is approximately a Critical Design Review level. Maturity of *Freedom*-derived designs is somewhat less than that, and maturity of other designs varies with the maturity of the source.

As can be seen from the Option A team organization and constituency data shown in Appendix A, Figures A-4 and A-5, and from the study schedule provided in Appendix A, Figure A-6, a wide breadth of disciplines was involved in the study. In addition to the technical study activities, several corollary efforts were pursued, as shown. Among these were cost assessment and management/acquisition strategy definition work. The work in these areas was coordinated closely with counterpart groups on the Station Redesign Team. This report does not include results from the corollary efforts.

Study requirements used by the SRT included: current Level I and Level II *Freedom* requirements, top-level requirements imposed by the NASA Administrator, requirements derived from existing international agreements, and other requirements defined by the team itself. Appendix B provides a top-level summary of the latter three categories of study requirements.

Additional data on Option A is provided in the MSFC briefing package MSFC SRT-001, *Final System Review to Space Station Redesign Team*, Revision B, June 10, 1993, and in the data books MSFC SRT-002, *Space Station Option A Modular Buildup Concept*, Volumes 1-5, Revision B, June 10, 1993.

All data from the Option A redesign activity will be provided to the NASA Transition Team for use in developing an implementation plan. During the development of this plan the results of the Option A study will be reassessed and adjustments made accordingly.

Table of Contents

Preface: Study Background and Approach	iii
Introduction	1
Description of Concept	3
External Configuration	3
Overall Configuration and Capability Levels	3
Design Elements	10
Optional Program "Stopping Points" Optimization	10
Internal Configuration	11
Mission Considerations	14
Orbital Inclination	14
Orbital Environments	14
Space Station Flight Modes	15
Propellant Utilization	17
Rendezvous Approach	19
Assembly Scenario	19
Assembly Flight Manifests	19
Assembly Operations	21
Assembly Operations Assessment	23
Systems/Subsystems	24
Bus-1 System Description	24
Guidance, Navigation, and Control Subsystem	26
Propulsion System	28
Electrical Power System	28
Thermal Control System	31
Communications and Data Management	34
Environmental Control and Life Support System	35
Habitability and Crew Systems	37
Structures and Mechanisms	39
Automation and Robotics	40
Reliability Assessment	40
Manufacturing Considerations (Facilities/Ground Support Equipment)	42
Test and Verification Plan and Philosophy	42
Integration Factors	43

Performance—Assessment of Capability	44
Key Requirements and Accommodation	44
General Requirements	44
Safety Requirements	44
General Science Accommodation Capability	45
Resources Available to Users	49
Accommodation of International Partners	50
Growth Capability	54
Potential Cost Savings Features	54
Transportation	55
Shuttle	55
Assured Crew Return/Soyuz	55
Spacelab	55
Specific Operations	56
Flight Operations	56
Ground Operations	56
Logistics and Utilization Approach	56
Maintenance/Spares Approach	57
Option A Unique Facilities/Ground Support Equipment	57
Technology Requirements and Opportunities	59
Top Level Cost	59
Schedules	60
Summary—Attributes and Issues	62
Appendix A: Station Redesign Teams and Timeline	63
Appendix B: Design Requirements	70

List of Figure and Table Captions

(In order as they appear in the text)

Figure 1	Modular buildup space station phases and potential stop capability points.	2
Figure 2	Assembly strategy.	2
Figure 3	Space station configurations.	4
Figure 4	Option A-1 (with Bus-1) Power Station and Human Tended Capability.	5
Figure 5	Option A-1 (with Bus-1) International Human Tended and Permanent Human Capabilities.	6
Figure 6	Option A-2 (without Bus-1) Power Station and Human Tended Capability.	7
Figure 7	Option A-2 (without Bus-1) International Human Tended and Permanent Human Capabilities.	8
Table 1	Option A subsystems weight summary.	9
Figure 8	Common module.	11
Figure 9	Common core/laboratory module.	12
Figure 10	Common habitation module.	13
Table 2	Option A weight summaries for common core/laboratory and common habitation modules (pounds).	13
Figure 11	Space station flight orientations.	15
Table 3	Space station flight orientation offset angles.	16
Figure 12	Option A-1 altitude time history.	18
Table 4	Propellant utilization budget.	18
Table 5	Option A assembly scenario, 28.8 degree inclination, 220 nautical mile altitude.	19
Figure 13	Launch weights for station assembly sequence, Option A-1, 28.8 degree inclination, 220 nautical miles.	20
Figure 14	Launch weights for station assembly sequence, Option A-2, 28.8 degree inclination, 220 nautical miles.	21
Table 6	Option A-1 assembly scenario, 51.6 degree inclination, variable altitudes.	22
Figure 15	Option A-1 space station assembly flight 4 operations.	22
Table 7	Extravehicular activities required for assembly.	23
Figure 16	Bus-1 guidance, navigation, control, and propulsion system (skin panels, avionics, and deployables not shown).	24
Figure 17	Option A-1 (with Bus-1) guidance, navigation, and control subsystem.	26
Figure 18	Option A-2 guidance, navigation, and control subsystem.	27
Figure 19	Electrical power system, modified distribution system.	29
Table 8	Electrical power system configuration for Options A-1 and A-2.	29
Table 9	Option A subsystems power summary at Permanent Human Capability, without orbiter, U.S. elements/systems only.	30
Figure 20	Available power example.	31

Figure 21	External active thermal control system overview schematic.	32
Figure 22	Internal thermal control system overview schematic.	32
Table 10	Space station thermal control system characteristics.	33
Figure 23	Communications and data management system.	34
Figure 24	Option A Environmental Control and Life Support System functions.	37
Figure 25	Laptop workstation.	38
Figure 26	Maintenance platform.	38
Figure 27	Space Station <i>Freedom</i> integrated truss assembly.	39
Figure 28	PDGF/POA locations for Mobile Service Structure translation and operation.	41
Figure 29	Testing and launch processing flow.	43
Figure 30	Option A-1 microgravity zones at International Human Tended Capability (view 1), arrow mode, without orbiter.	46
Figure 31	Option A-1 microgravity zones at International Human Tended Capability (view 2), arrow mode, without orbiter.	46
Figure 32	Option A-1 candidate attached payload locations.	47
Figure 33	Option A-2 candidate attached payload locations.	48
Table 11	Resources available to users.	50
Figure 34	Option A-1 available payload power comparison.	51
Figure 35	Option A-2 available payload power comparison.	52
Table 12	Summary of Option A impacts on International Partner Memorandums of Understanding.	53
Table 13	Shuttle performance data.	55
Table 14	Utilization, logistics, and outfitting flights for Option A-1 and A-2 at 28.8 degrees inclination, standard external tank, no advanced solid rocket motor.	58
Figure 36	Option A launch schedule, with standard external tank.	60
Figure 37	Option A-1 schedule.	61
Figure A-1	Advisory committee on the redesign of the space station (Blue Ribbon Panel).	63
Figure A-2	Station Redesign Team.	64
Figure A-3	Station Redesign Team members.	65
Figure A-4	MSFC Option A station redesign study team.	66
Figure A-5	MSFC station redesign support team members.	67,68
Figure A-6	MSFC station redesign study team schedule.	69

Introduction

Option A is a unique modular concept responsive to the overall station redesign requirements, while emphasizing programmatic and design solutions that result in a reduced size and cost station. The Option A concept concentrates on program approaches that offer significant management, design, and operations cost reduction options for a space station while keeping a strong focus on maintaining key science and research capabilities, international commitments, and other objectives. Two very similar, viable options have been defined (Option A-1 with a Bus-1 spacecraft and Option A-2 without the Bus-1). Either option offers good user responsiveness as it builds toward permanent human presence, and either is capable of stopping at any of three intermediate capability levels. Both options are discussed in this report.

Specific key design drivers on the option configurations and systems are: (1) accommodation of microgravity (micro-g) sciences, life sciences, and other sciences, including internal and external payload accommodations; (2) accommodation of the Space Station *Freedom* international partners' elements with minor impacts; (3) constrained development and life cycle cost; (4) utilization of current Space Station *Freedom* investment; (5) achievement of initial orbital research capability by 1997; (6) a reasonable number of assembly flights to achieve permanent human capability; (7) minimization of extravehicular activity for assembly and maintenance; and (8) crew and mission safety.

The modular buildup approach incorporates four buildup phases: Phase 1 provides a Power Station to which payloads or a space shuttle with Spacelab can attach; Phase 2 provides a Human Tended Capability by adding a pressurized laboratory with docking ports and some international equipment; Phase 3 provides an International Human Tended Capability through the addition of large international payload elements; and Phase 4 provides a Permanent Human Capability by addition of other elements. If cost constrains the capability of the station, it could be optimized for improved performance at any of these four phases, and such potential changes are identified herein. The most efficient and effective operations are attained, of course, at Permanent Human Capability, so station buildup desirably would continue to that point to achieve full attributes of permanent human presence in space, a primary goal.

Option A uses current and simplified Space Station *Freedom* systems where cost-effective, with several repackaged, reduced, and simplified elements to reduce overall costs, assembly flights, and extravehicular activity. Existing systems were considered where practical. An example is the Lockheed Missiles and Space Company's Bus-1 spacecraft for Option A-1 guidance, navigation, control, and propulsion. Selected shuttle orbiter/Spacelab systems, Russian systems, and limited commercial hardware were also assessed and incorporated into both Options A-1 and A-2.

The deployment and assembly strategy of Option A is to initiate deployment in October 1997, with a rapid three-flight buildup to a Power Station. This is followed by a slower buildup to Permanent Human Capability, with two additional potential stop or temporary use points—Human Tended Capability and International Human Tended Capability. Figures 1 and 2 reflect this launch and buildup strategy for a station at 28.8 degrees orbit inclination, and the resulting capability levels. The same strategy, same schedule, and same resulting configurations would apply at orbit inclinations of 43 degrees and 51.6 degrees, but require the use of aluminum lithium external tanks, occasional use of variable altitude strategies, and off-loading of some module racks; availability of the advanced solid rocket motor would significantly enhance the assembly scenarios for these cases and would enhance logistics scenarios for all cases.

Orbiter visits to the station during the buildup time frame are a maximum of 16-20 days duration; longer visits would be incorporated if there are no prohibitive crew medical constraints. In the Permanent Human Capability phase, orbiter visits are intentionally kept shorter (7 days), since a station crew is on orbit continuously. The orbiter uses power from the station in the first three phases. Utilization flights are interspersed with assembly flights in the buildup sequence to enhance early payload operation, but if cost or other constraints dictate, these could be reduced for streamlining or acceleration of the buildup. Some utilization flights include partial complements of logistics or other equipment, but each is primarily payload-related.

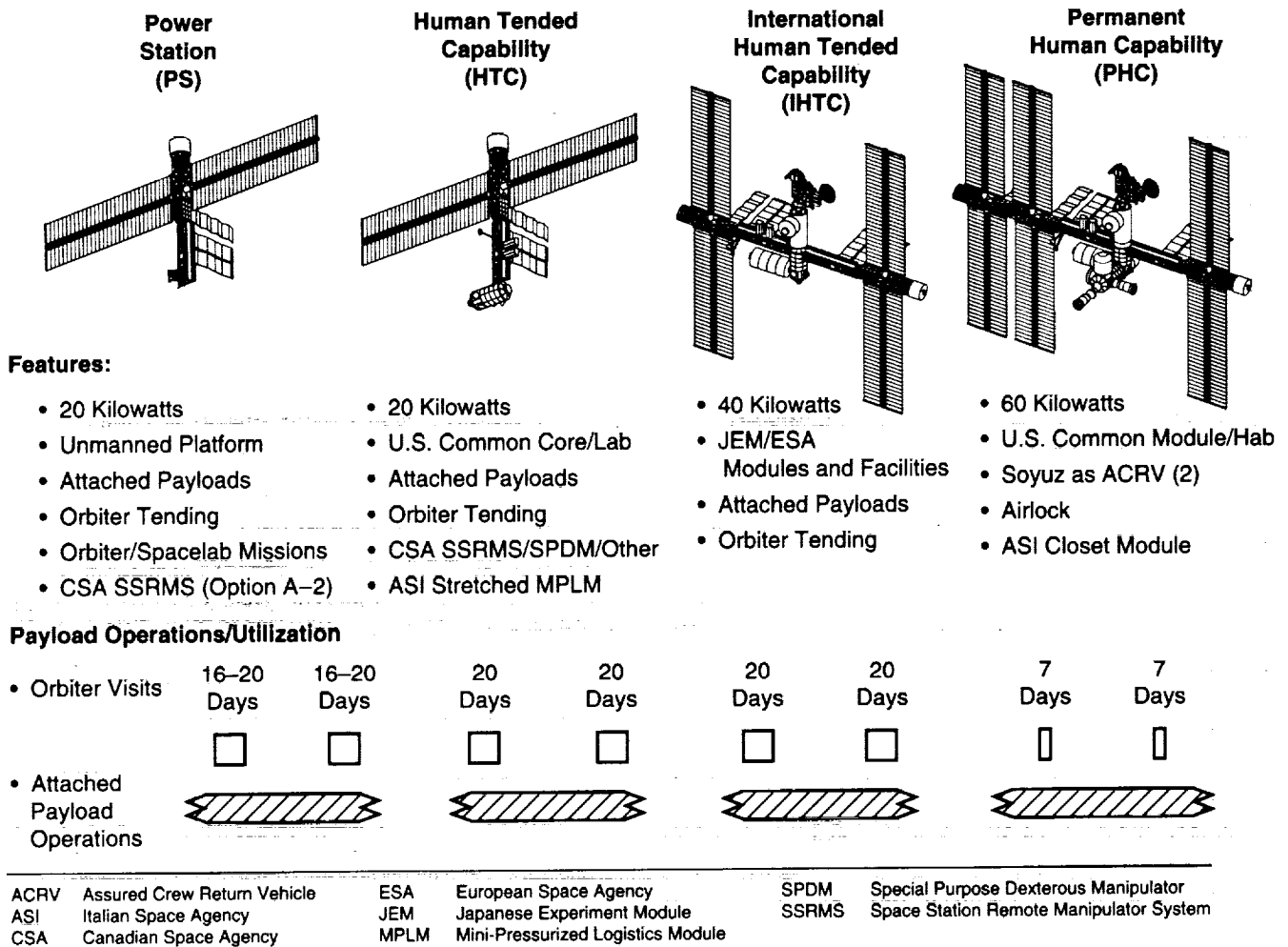

Figure 1.—Modular buildup space station phases and potential stop capability points.

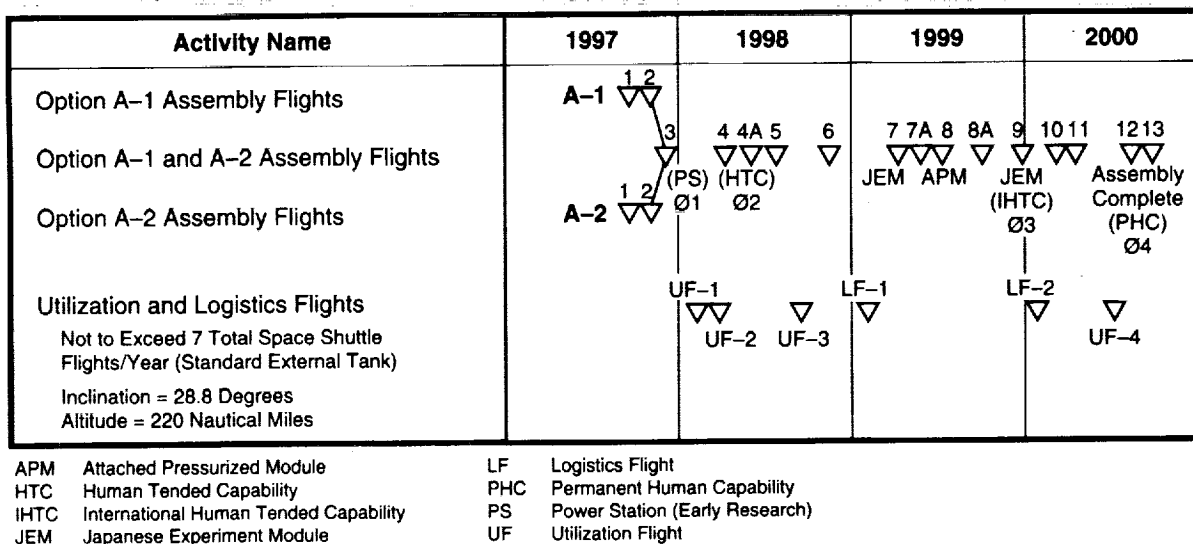

Figure 2.—Assembly strategy.

Description of Concept

External Configuration

Overall Configuration and Capability Levels

The Option A configurations draw significantly from Space Station *Freedom* elements and other applicable hardware, such as Bus-1 for Option A-1. These are integrated to provide a viable station supporting national and international goals, but at a lower cost and with fewer assembly flights than Space Station *Freedom*. Options A-1 and A-2 are schematically compared to Space Station *Freedom* in Figure 3, which shows the overall configuration and major element differences between the options.

Both Option A approaches are considered evolutionary. The configurations at the four capability levels or plateaus are shown in Figures 4 and 5 for Option A-1 and in Figures 6 and 7 for Option A-2. For both options, the Power Station is established after three assembly flights, and includes power generation (20 kilowatts), thermal control, avionics, reboost, and attitude control capability. Human Tended Capability adds a Common Core/Lab (laboratory with multiple docking ports), and is achieved after four assembly flights. The Canadian Space Agency's Mobile Servicing System is partially available in Phase 1 (Option A-2) and completely operational in Phase 2 for both options. The Italian stretched Mini-Pressurized Logistics Module begins operation in Phase 2. International Human Tended Capability occurs after 12 assembly flights. During this phase, additional power generation (40 kilowatts total); additional thermal control; a cupola; the Japanese Experiment Module; the European Space Agency's Attached Pressurized Module; and the Japanese Experiment Module's Exposed Facility, Experiment Logistics Module, and Exposed Section are added. Permanent Human Capability, which is attained after 16 assembly flights, provides additional power equipment (60 kilowatts total), a Common Module/Hab (crew habitability with additional docking ports), airlock, a Closet Module derived from the Mini-Pressurized Logistics Module, and two Russian Soyuz vehicles which serve as assured crew return vehicles.

The general arrangement for Options A-1 and A-2 are similar, but there is a 90 degree difference between A-1 and A-2 in the relative orientations of the truss faces and deployed solar arrays. Both options work well, and either option could be configured either way if a preference is established. The relative orientation of the solar array and the central truss on Option A-2 is driven by the pre-launch mating of the power system and first truss section. Due to the truss design, the orientation must be maintained when the inboard truss and radiator system is attached. Option A-1 requires fewer inboard truss segments than A-2, since it does not have attached propulsion modules, but it does require a new transition structure. This new transition section allows the inboard and outboard radiators to be aligned. The module pattern for both options is driven strongly by clearance for the Shuttle Remote Manipulator System during assembly, and by payload viewing requirements. The external configurations and module patterns for Options A-1 and A-2 could look the same, as noted previously, except for Bus-1.

The overall dimensions at Permanent Human Capability for Option A-1 are 245 feet in length with a wingspan of 248 feet, and for Option A-2 are 281 feet in length with a wingspan of 248 feet. This compares to a length of 355 feet and a wingspan of 248 feet for Space Station *Freedom*. The weight of the assembled elements, including payloads, at each phase is given in Figures 4 through 7. The accumulated subsystem weights on orbit (excluding payloads) is compared to *Freedom* systems in Table 1. The weight and power values used in this report were based on "actual" data inputs to the Space Station *Freedom* Level II Resource Margin Summary dated February 1993.

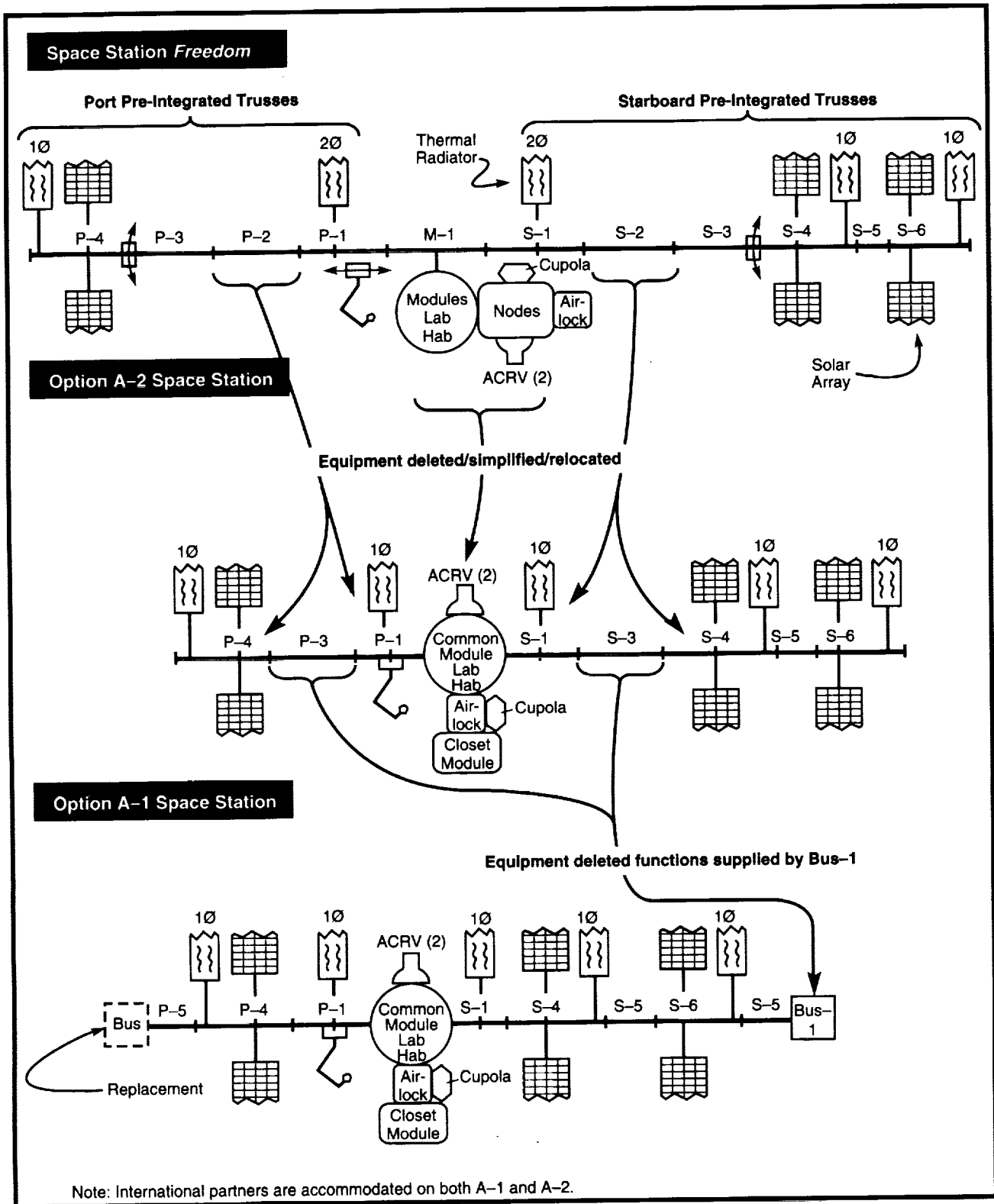

Figure 3.—Space station configurations.

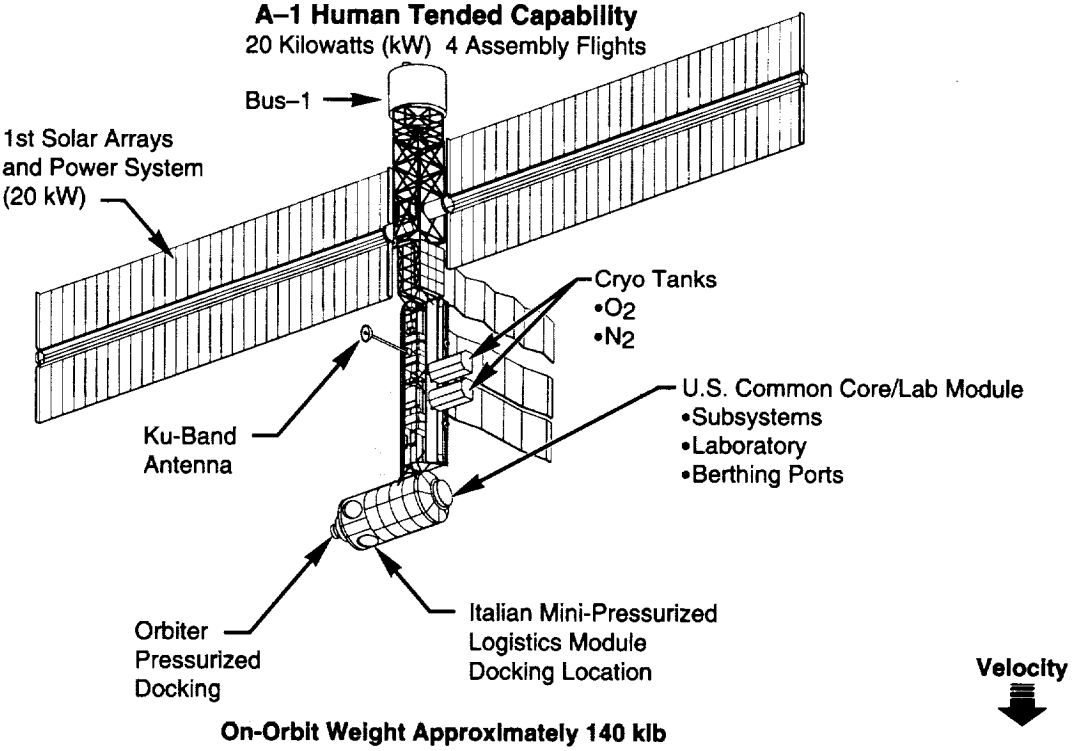
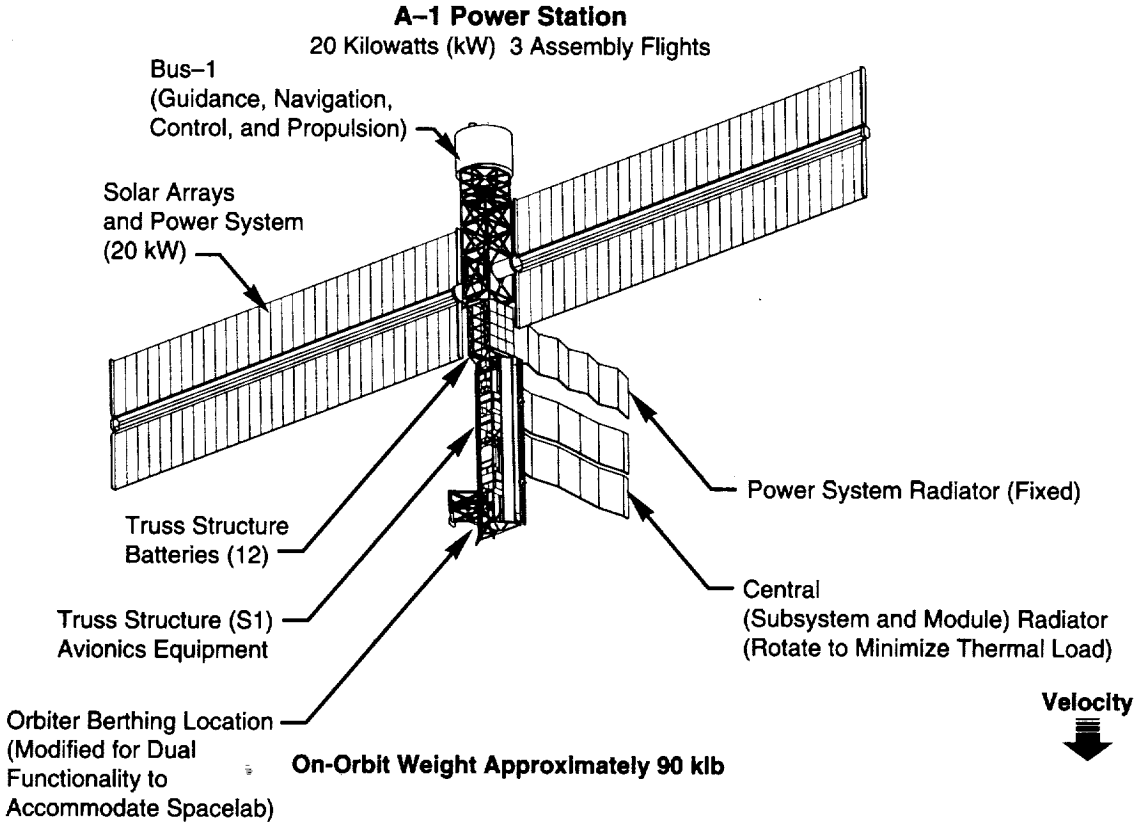
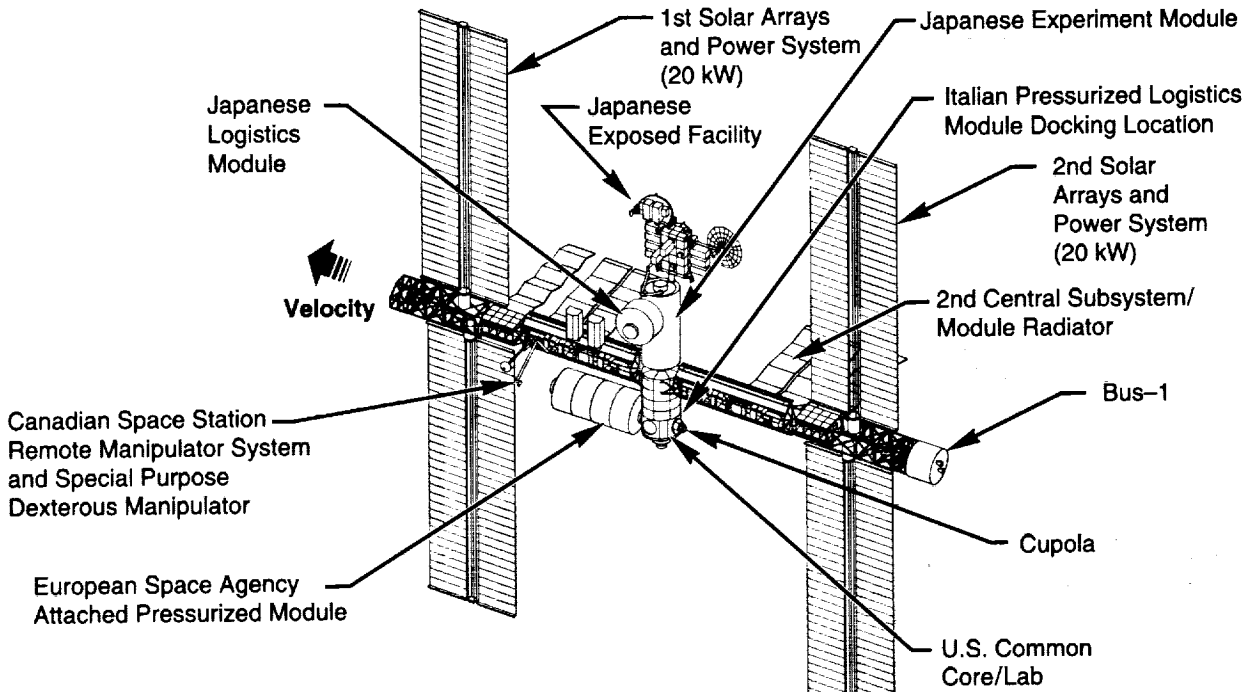

Figure 4.—Option A-1 (with Bus-1) Power Station and Human Tended Capability.

A-1 International Human Tended Capability

40 Kilowatts (kW) 12 Assembly Flights



On-Orbit Weight Approximately 350 klb

A-1 Permanent Human Capability

60 Kilowatts (kW) 16 Assembly Flights

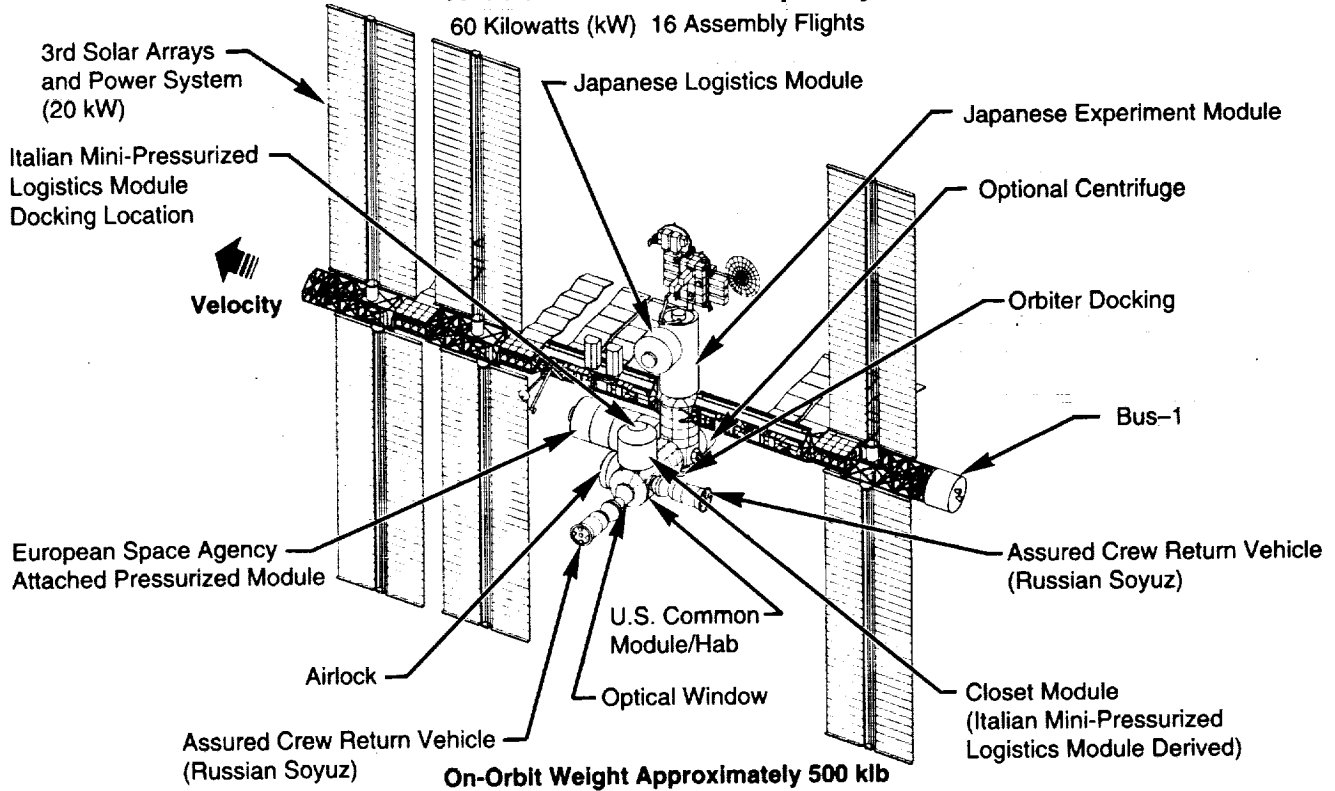

On-Orbit Weight Approximately 500 klb

Figure 5.—Option A-1 (with Bus-1) International Human Tended and Permanent Human Capabilities.

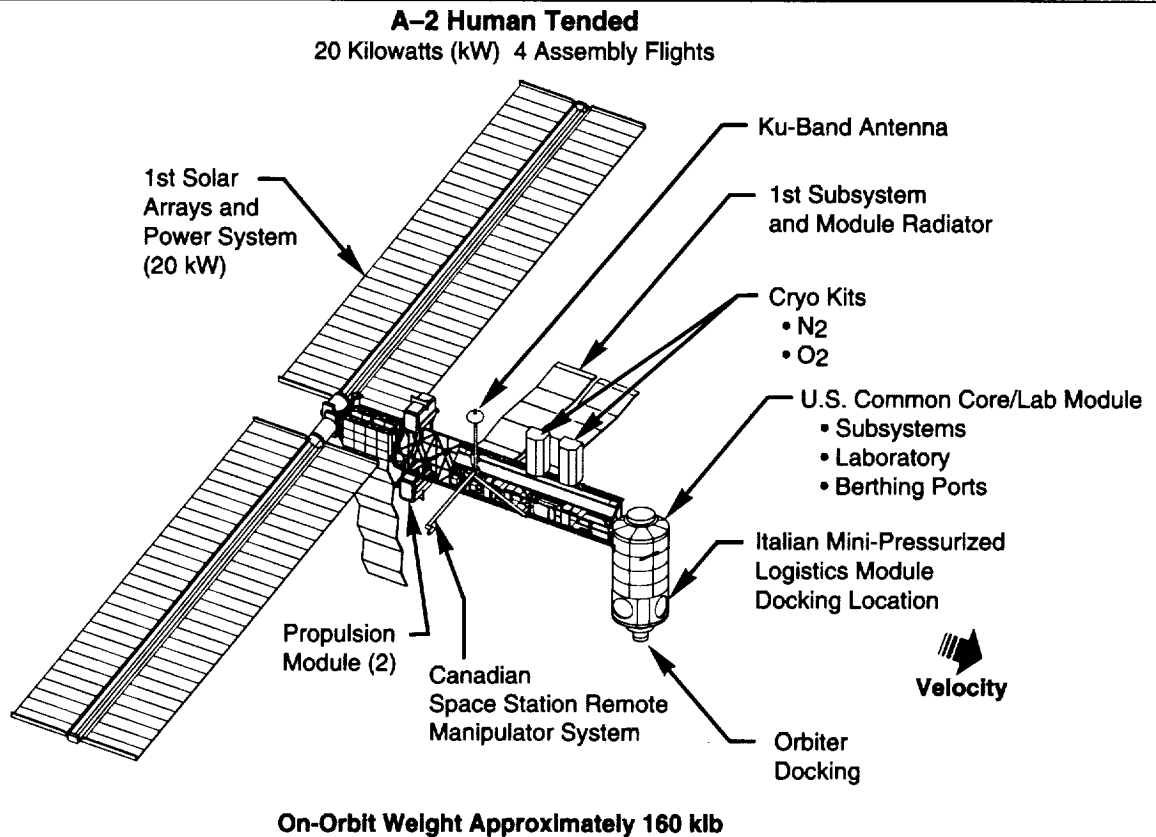
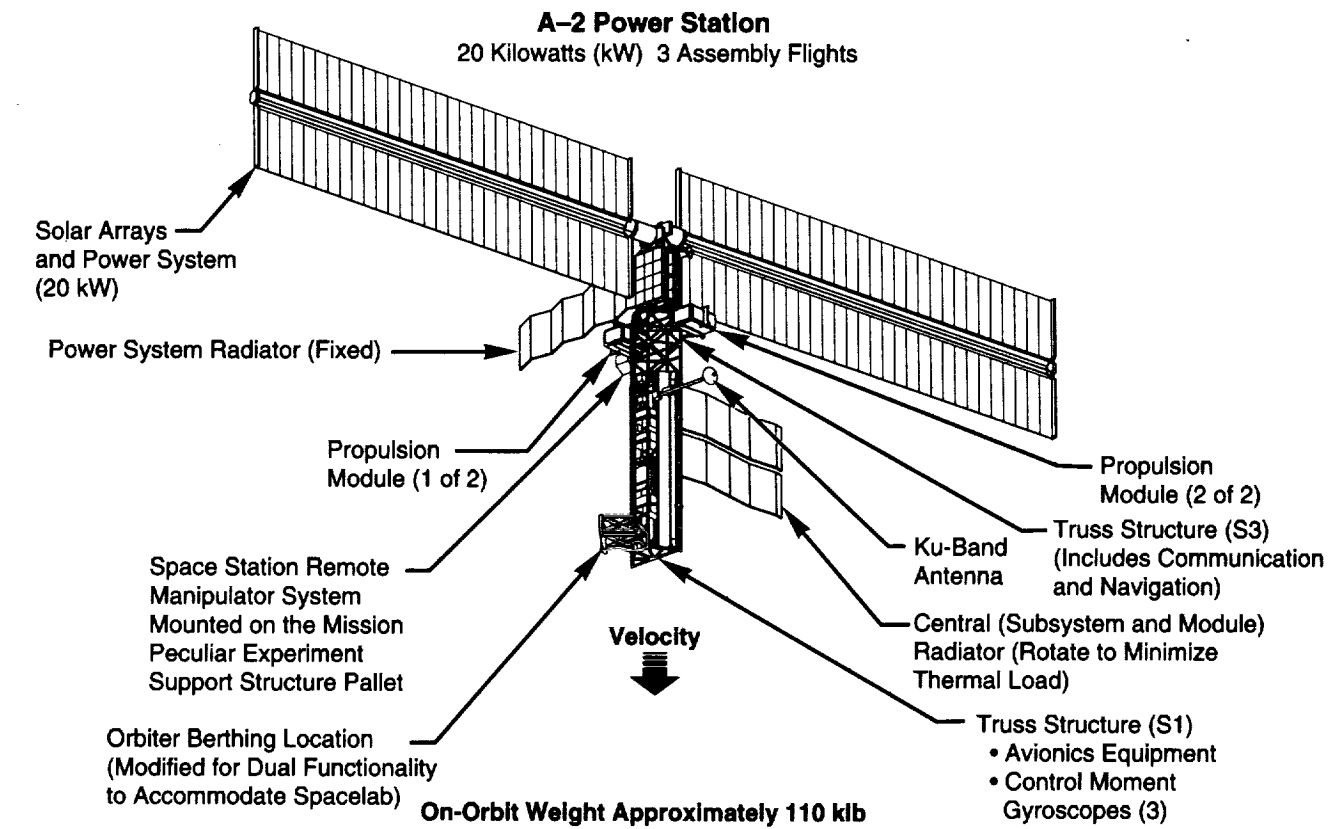
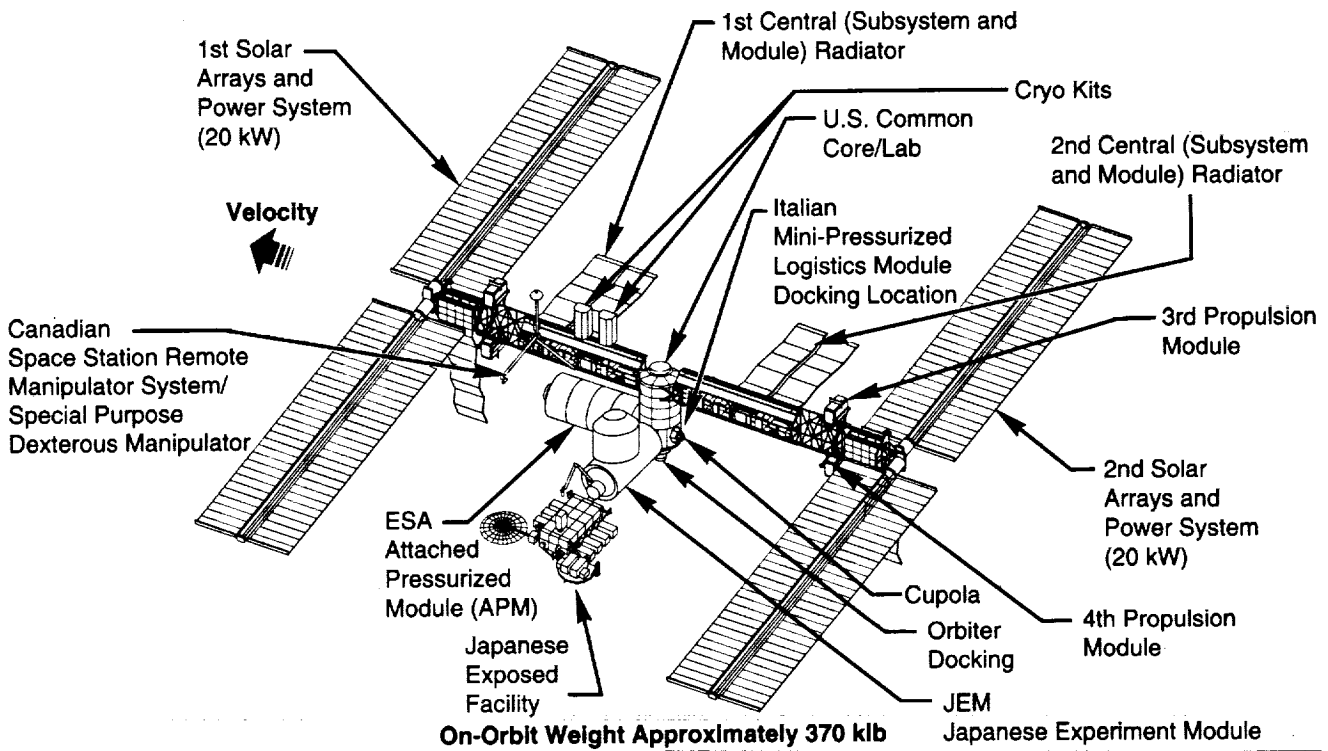

Figure 6.—Option A-2 (without Bus-1) Power Station and Human Tended Capability.

A-2 International Human Tended Capability

40 Kilowatts (kW) 12 Assembly Flights



A-2 Permanent Human Capability

60 Kilowatts (kW) 16 Assembly Flights

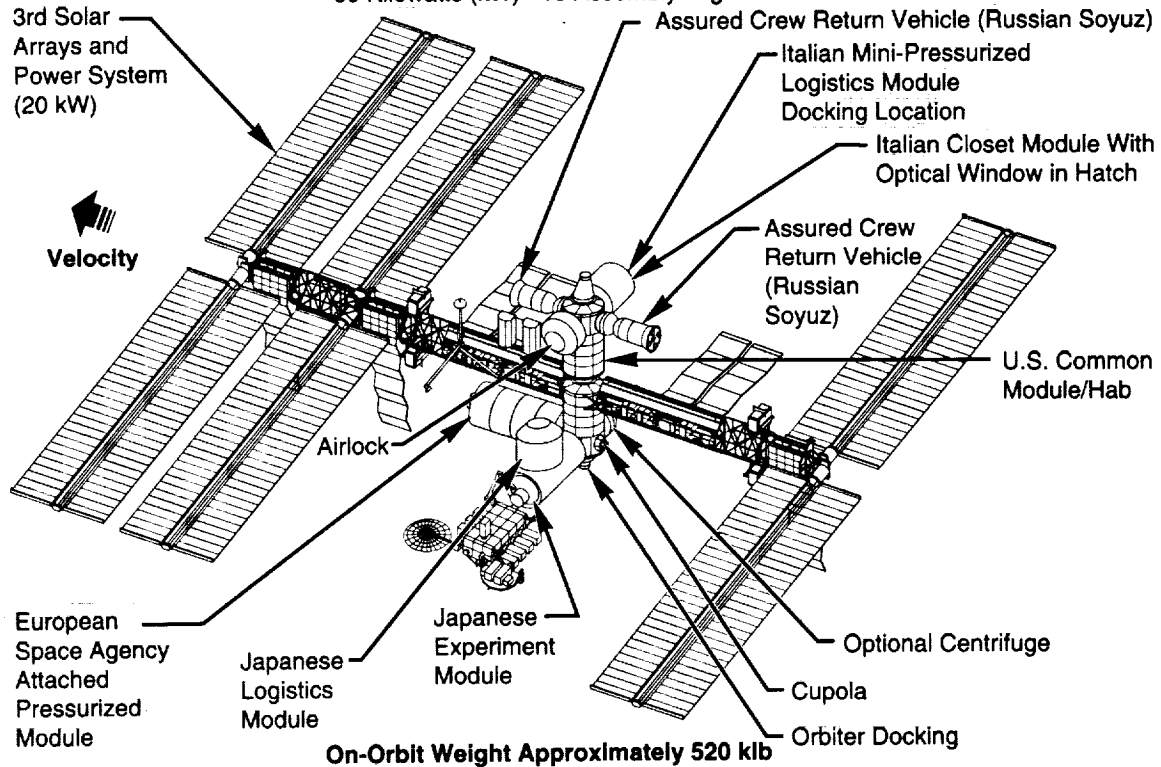

Figure 7.—Option A-2 (without Bus-1) International Human Tended and Permanent Human Capabilities.

Table 1.—Option A subsystems weight summary.

Subsystem	Launch Weight (Pounds)		
	Space Station <i>Freedom</i>	A-1	A-2
Data Management	10,341	6,720	6,330
Electrical Power Generation	34,852	27,700	30,127
Power Distribution and Control	29,193	19,237	14,793
Communications and Tracking	3,323	2,400	2,269
Environmental Control and Life Support System	19,304	9,266	9,266
Thermal Control	33,399	31,460	28,880
Crew Health Care System	(Note 1)	1,653	1,653
Crew Systems	10,767	3,621	3,621
Propulsion	29,412	1,755	18,835
Structures	166,623	132,670	143,521
Mechanical Systems	38,418	9,454	9,435
Guidance, Navigation, and Control	2,819	3,444	1,868
Extravehicular Activity	9,202	666	1,176
Utilities	(Note 2)	(Note 2)	(Note 2)
Consumables	30,292	17,140	19,360
Bus-1 Additions	0	1,121	0
Total U.S. Systems Subtotal	417,945	268,306	291,132
Italian Mini-Pressurized Logistics Module	11,639	9,771	9,771
Russian Assured Crew Return Vehicles	17,530	29,693	29,693
European Space Agency	31,405	28,980	28,980
Japanese Experiment Module	58,643	65,260	65,260
Canadian Space Agency	10,841	6,357	6,357
Total	548,003	408,367	431,193

Notes:

- Weights are actuals, from Space Station *Freedom*, Feb. 1993, Level II Resources Margin Summary, and from Lockheed Missiles and Space Company's Bus-1 data.
- Weights do not include flight support equipment, payloads, or 1,800 pound Space Station Manager's margin per flight.
- "Consumables" include crew consumables, propellants, and cryos.

(1) Included in crew systems weights.

(2) Included in subsystems weights.

Design Elements

Option A utilizes elements from Space Station *Freedom*. However, hardware is deleted where possible, simplifications are made in other cases, and substitutions are taken from existing programs. Major changes from Space Station *Freedom* include: deletion of some truss sections (five in Option A-1 and three in Option A-2), use of a Common Core/Lab module and a Common Module/Hab rather than nodes plus modules, use of a simplified solar array/battery system, deletion of alpha joints, use of a single-phase rather than two-phase radiator system, major simplifications in the data management system and associated software, use of a simplified and smaller airlock derived from elements of the module, reliance on a stretched Mini-Pressurized Logistics Module with deletion of the Pressurized Logistics Module, use of a Closet Module derived from the Mini-Pressurized Logistics Module, and reduction of about 30 percent in orbital replacement units. A more detailed list of deletions is provided in the section on Potential Cost Savings Features.

When present, the orbiter is relied upon to provide significant human support through the International Human Tended Capability phase, including the external airlock and selected extravehicular activity and crew support equipment. Option A hardware includes an 8 inch optical window from Spacelab, laptop computers, and some extravehicular activity tools from commercial sources and other NASA programs, Bus-1 for Option A-1, and use of two Russian Soyuz spacecraft as assured crew return vehicles. Other potential uses of Russian equipment include hardware for closure of the environmental control and life support system oxygen loop, and select use of docking hardware.

Optional Program "Stopping Points" Optimization

Each phase offers reasonable capabilities for interim station operation/utilization during the buildup sequence. If the program is permanently stopped at one of these phases, adjustments should be made to optimize the station for operation at that phase. If buildup stopped at the Power Station phase, the Space Station Remote Manipulator System (already present on Option A-2), Special Purpose Dexterous Manipulator, and payload/orbital replacement unit accommodation equipment would be added for maintenance support. A video and high-rate data communications system would be added. One external radiator and all laboratory umbilicals would be eliminated. The reboost thrusters on the propulsion module (Option A-2) would be relocated. Additional mounting locations for external payloads would be provided. There would be no resulting reduction in capability at the Power Station phase.

If buildup stopped at Human Tended Capability, Option A would utilize either a Common Core/Lab or a U.S. laboratory module. The orbiter would be rotated 90 degrees and docked parallel to the external truss to provide an improved microgravity environment for payloads. The Space Station Remote Manipulator System, Special Purpose Dexterous Manipulator, and payload/orbital replacement unit accommodation equipment would be added prior to completing this modified Human Tended Capability phase. Umbilicals for the international modules and the Common Module/Hab would be deleted, and reboost thrusters on the propulsion module (Option A-2) would be relocated. There would be no resulting reduction in capability at the Human Tended Capability phase. If buildup stopped at International Human Tended Capability, the primary change would be deletion of scars for oxygen generation equipment.

Internal Configuration

The Space Station *Freedom* design includes two basic types of pressurized elements: (1) a module and (2) an interconnect node. The modules, outfitted as laboratory or habitation modules, are interconnected by nodes. Option A combines these two types of pressurized elements to form the common module, shown in Figure 8. A common module provides the functions of a node and is also outfitted as a laboratory or habitation module, with a pressurized mating adapter on an axial port for orbiter mating. The common module serves as the building block for the pressurized elements comprising Option A.

Orbiter launch weight limits preclude a simple merger of the two elements. Instead, the outfitted volume of the common module is reduced by one-third relative to a Space Station *Freedom* module to accommodate the addition of four radial berthing ports. Although less volume is provided for outfitting, the mission requirements for habitation and laboratory modules are accommodated well by the common module. Through a combination of phased mission requirements definition (e.g., definition of stowage requirements by Human Tended Capability, International Human Tended Capability, and Permanent Human Capability), subsystems simplification (e.g., a single type of data management system network), and elimination of equipment duplicated in the Space Station *Freedom* modules and nodes, the quantity of outfitting volume needed to comprise a laboratory or habitation module can be reduced by approximately one-third, coincident with the outfitting volume available in a common module.

The rack-based outfitting method employed within the Space Station *Freedom* pressurized modules is retained within the common module. This method symmetrically arranges the racks in four quadrants within the cylindrical section of the module. One row of adjacent racks constitutes the floor, the opposite row forms the ceiling, and the other two rows form the port and starboard walls. This commonality with the Space Station *Freedom* modules allows the common module to incorporate significant portions of existing designs for the primary and secondary structure, utility routing, and rack and end cone packaging.

When outfitted as a laboratory, the common module provides nine rack locations for International Standard Payload Racks—three each in the ceiling and in the port and starboard walls as depicted in Figure 9. Other racks include: stowage; atmosphere revitalization; cabin air, temperature, and humidity control; condensate water storage; thermal control; and avionics (data management, audio, video, communications, and electrical power). The topology is largely driven by the International Standard Payload Rack utility interfaces with the module; for example, providing the International Standard Payload Rack utility interface plates in both floor and port wall locations would hinder service access to utility lines within that structure. Likewise, the packaging of subsystem equipment in the module end cones precludes location of an International Standard Payload Rack adjacent to the end cone. Another consideration was the objective of maximizing commonality with the existing design of the Space Station *Freedom* Laboratory module. The foregoing considerations form the principle constraints leading to the topology shown in Figure 9.

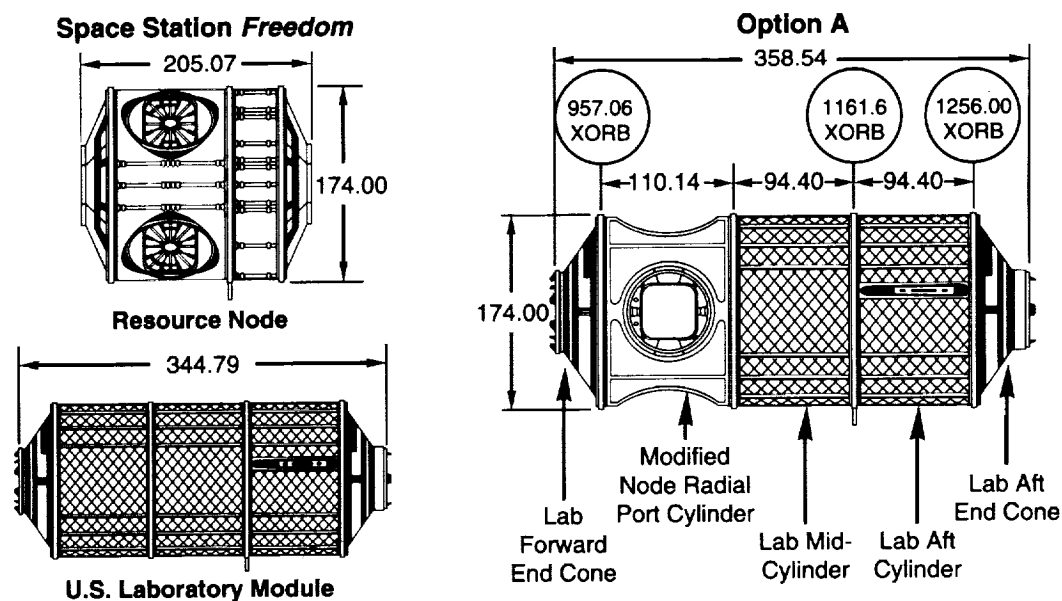

All measurements are given in inches.

Figure 8.—Common module.

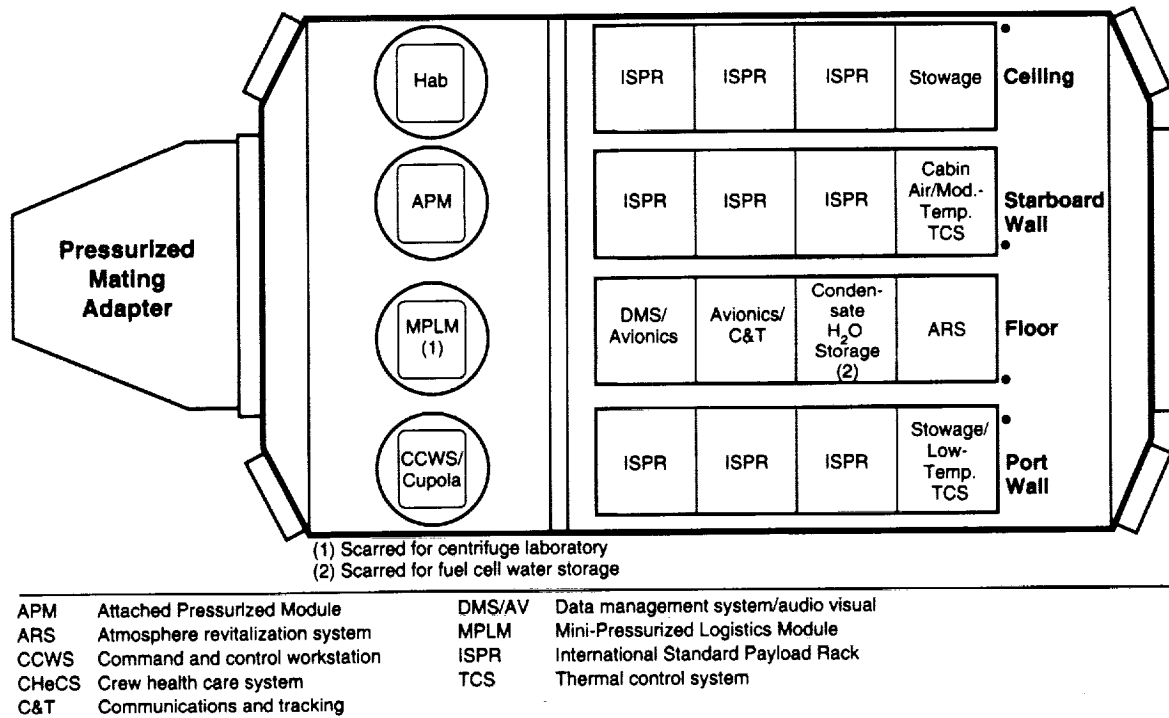

Figure 9.—Common core/laboratory module.

A Spacelab 8 inch diameter optical quality window is included in one hatch to allow crew viewing and Earth/sky scientific observation. The viewing flexibility of this single window is significantly enhanced by the Option A attitude control method; periodic plus and minus 90 degree reorientations about the long axis of the truss are employed to maximize electrical power production. The rationale of this attitude control methodology is discussed in the section on Space Station Flight Modes. At International Human Tended Capability, crew viewing and observation is further enhanced through addition of a cupola to the laboratory module. When the cupola is added, the robotics workstation, formerly located in an unused radial port, will be redeployed in the cupola, facilitating control of the Mobile Servicing System and the Special Purpose Dexterous Manipulator by allowing direct viewing of selected Mobile Servicing System operations.

By adding central thermal bus heat exchangers and primary power feedthroughs to a common module, a mating module can be attached without extravehicular activity. The common module acts as the "core" module in that a mating module receives all station services via its interface to the common module. The common module accommodates this

core capability without significant technical impacts. The Common Core/Lab presently provides the core capability for the attachment of the European Space Agency's Attached Pressurized Module. Core capability is also provided for the Common Core/Lab thermal system interface with the Japanese Experiment Module. Extravehicular activity is still required to connect electrical power to the Japanese Experiment Module, but this is under study.

The topology for a common module outfitted as a habitation module is shown in Figure 10. The design will accommodate a crew of four for 90-day missions, plus a crew of 10 for the week overlap of crews between missions. The Common Module/Hab includes a wardroom, galley, shower, waste management compartment, laundry, refrigerator/freezer, sleep accommodations, and crew health care system accommodations. These items are either identical to or slightly modified from the Space Station *Freedom* designs. The allocated sleep volume, including storage, is the same as that provided aboard Skylab, proven adequate for an 84-day mission. The sleep restraints are in potential dual-use locations and further study is required to determine the suitability of these locations. The crew health care system exercise facility is deployed on orbit in a radial port location.

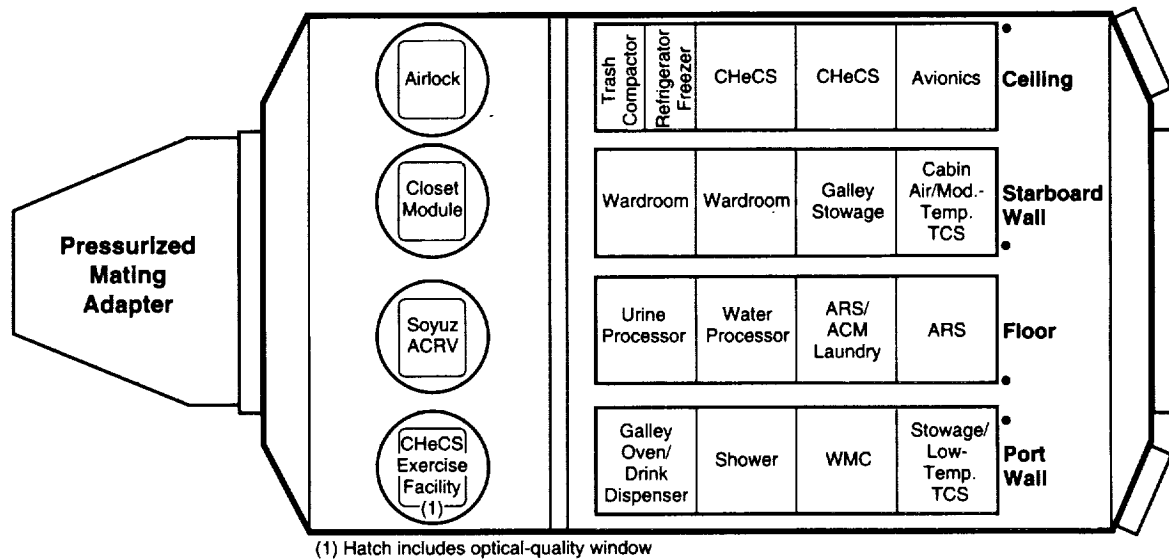

ACM	Atmosphere control and monitoring	C&T	Communications and tracking
ACRV	Assured crew return vehicle	DMS/AV	Data management system/audio visual
APM	Attached Pressurized Module	MPLM	Mini-Pressurized Logistics Module
ARS	Atmosphere revitalization system	ISPR	International Standard Payload Rack
CCWS	Command and control workstation	TCS	Thermal control system
CHeCS	Crew health care system	WMC	Waste management compartment

Figure 10.—Common habitation module.

Table 2.—Option A weight summaries for common core laboratory and common habitation modules (pounds).

Subsystem	Laboratory*	Habitation
Structures	14,216	14,074
Mechanisms	3,508	3,138
Data Management	2,453	2,275
Environmental Control and Life Support System	3,598	4,295
Electrical Power	1,739	1,402
External Thermal Control	286	226
Extravehicular Activity	63	63
Internal Audio/Video	506	467
Internal Thermal Control	2,347	2,164
Crew Systems	1,161	928
Vacuum Vent	1,081	0
Total	30,958 lb	29,032 lb

* Excluding International Standard Payload Racks

Stowage volume for crew durable items and consumables is provided by the Common Module/Hab, the European Space Agency's Attached Pressurized Module, the Japanese Experiment Module, and a Closet Module, which is a modification of the Mini-Pressurized Logistics Module provided by the Italian Space Agency. The Closet Module is permanently attached to a Common Module/Hab radial port and serves as a pantry for the station as well as providing other required stowage volume. The total station stowage includes a short duration (14 day) food supply in the Common Module/Hab galley, with remaining food in the Closet Module. Consumables required for a 45-day skip cycle are provided.

The weight summaries of a common module, outfitted as core laboratory and habitation modules, are given in Table 2. The weights for the laboratory module include all on-orbit equipment at Permanent Human Capability except payloads (International Standard Payload Racks). The habitation module is also launched partially outfitted; outfitting is completed on subsequent flights, comparable to the Space Station *Freedom* concept. The fully outfitted common module weights are in the 39–42 klb range.

Mission Considerations

Orbital Inclination

Three potential orbital inclinations were considered for the space station. The first was a low inclination of 28.8 degrees, consistent with the Space Station *Freedom* program, and two higher ones were 43 and 51.6 degrees. The majority of this report deals with the 28.8 degree inclination, with limited discussion also provided on others.

Inclinations above 33 degrees allow dual access to the space station from the U.S. and Russian launch sites, but the higher inclinations significantly penalize space shuttle performance. At lower inclinations, the station can utilize the standard shuttle external tank and be assembled at the operational 220 nautical mile orbit. The pressurized module launches will require some off-loading or downsizing if advanced solid rocket motors are not available. At 43 degrees, an aluminum lithium external tank is required, and the assembly is identical to that at 28.8 degrees. Placement at 51.6 degrees inclination requires: an aluminum lithium external tank, beginning with the first assembly flight; occasional assembly at lower orbits ranging from 170 to 200 nautical miles; greater off-loading or downsizing of pressurized modules; and a stronger need for the advanced solid rocket motor. Assembly manifests for 28.8 and 51.6 degree inclinations are addressed in the section on Assembly Flight Manifests. Launch windows are also more constrained for the high inclinations, which impact payload delivery and phasing flexibility. Assembly missions at the 28.8 degree inclination have launch windows of 52 minutes, whereas the windows decrease to 5 minutes at 51.6 degrees; these can be lengthened, but at considerable penalty in shuttle performance capability.

A small advantage in power generation is realized at high inclinations, since the length of time in sunlight increases with inclination. The 28.8 degree inclination orbit eventually provides up to 48 percent overflight of the Earth and an equal percentage of zenith celestial sphere viewing coverage. The 51.6 degree inclination orbit allows 78 percent coverage of the Earth or celestial spheres. The micrometeoroid and radiation environments are more favorable at the 28.8 degree inclination, with the orbital debris environment being about 12 percent worse for a 51.6 degree inclination orbit.

Orbital Environments

Micrometeoroid and Orbital Debris, Ionizing Radiation, and Sun Exposure

An analysis has been performed to determine the effects of the micrometeoroid and orbital debris environment on the Option A space station. This analysis has taken into account the latest meteoroid and orbital debris environment model, the different flight orientations, the orbital inclinations, and the protection designs for the various critical elements. The results showed that the probability of no penetration for the Option A space station designs range between 70 and 80 percent for 10 years, depending on the configuration and orientation. A meteoroid and orbital debris enhancement study for Space Station *Freedom* is nearing completion. When implemented, results of this study will improve the overall space station protection to approximately 90 percent probability of no penetration. The probability of no penetration for any individual critical system is higher than that for the overall station. The overall probability of no penetration for Option A may be better than for Space Station *Freedom* due to the reduced number of critical elements and increased protection provided by noncritical elements.

Radiation dose rates outside the space station modules will be 6–10 times higher at 51.6 degrees than at 28.8 degrees. This increase is mitigated relative to *Freedom* by the reduction in operational lifetime from 30 to 10 years. The combination of higher dose rates and shorter exposure times results in the total dose being increased by a factor of 2–3.

Flux levels of particles with high linear energy transfer, which produce single-event effects in microelectronic devices, is significantly higher at 51.6 degrees. In general, systems designed for 28.8 degrees should be compatible with the 51.6 degree inclination environment. The exception is for systems susceptible to single event effects. These systems should be reassessed for compatibility with the 51.6 degree environment. Doses from solar flare particle events will not be significant at either 28.8 degrees or 51.6 degrees because of the shielding provided by the Earth's magnetic field. In summary, the higher inclination imposes no significant impact to the space station and its inhabitants, but reassessment of some systems should be made to assure compatibility.

The 28.8 degree and 51.6 degree orbital inclinations give maximum beta angles of 52.3 degrees and 75.1 degrees, respectively. At 28.8 degrees with an altitude of 220 nautical miles, the time in sunlight per orbit varies from 61 to 68 percent. At 51.6 degrees and 220 nautical miles, the time in sunlight varies from 61 to 100 percent; continuous sunlight time occurs three to four times per year and has a maximum duration of 5 days.

Solar Inertial Flight Mode

With the station oriented in a fixed attitude with respect to a solar inertial frame of reference, the problem of solar arrays shadowing one another is minimized. The station could always be oriented so that the arrays face the Sun while simultaneously placing the thermal radiators in the shadow of the truss or the solar arrays. In a solar inertial flight orientation, the space station would exhibit large gravity gradient torques (both secular and cyclic) which cause the control moment gyros to saturate rapidly. Frequent propellant expenditure or reorientation of the station throughout the orbit would be required to desaturate the control moment gyros. This makes the solar inertial flight orientation unfeasible for Option A, from a momentum management viewpoint. Payload accommodations in the solar inertial orientation would be severely compromised. This orientation would provide constant pointing for solar or celestial viewing, but since the station would be constantly rotating with respect to the Earth, surface viewing capability would be poor and microgravity processes that depend on directional stability would be penalized.

Arrow/Combination Flight Mode

For station configurations having dual or triple solar arrays, there would be times during which some arrays would be in the shadow of other arrays, diminishing the performance of the shaded arrays. Shadowing is a function of the array dimensions and spacing, and the orientation of the solar vector with respect to the space station. The worst case shading would occur when the solar vector was in line with the space station truss; this would cause all but one array to

be completely shaded. In the true arrow/combination flight mode, the large secular gravity gradient torques would cause rapid control moment gyro saturation similar to that in the solar inertial mode. Therefore, this flight mode would also suffer large propellant and momentum management penalties, as in the solar inertial flight mode. The Earth and celestial viewing capability in the arrow/combination flight mode would be generally acceptable. It was determined that 73 percent of the time would be spent in an orientation with the solar arrays perpendicular to the orbit plane; instruments could be attached to the station to achieve favorable viewing during this time. The microgravity conditions would be excellent. The only disturbances would occur during the periodic reorientations (90 degree rotations) which occur at a varying interval of 8 to 56 days.

Torque Equilibrium Attitude/Combination Flight Mode

The torque equilibrium attitude/combination flight mode is similar to the arrow/combination flight mode except that the space station attitude is slightly offset or skewed from the "ideal" orientation. When the orbiter is not docked to the station, these offsets are very small, so the station would be very near the arrow orientation. In the torque equilibrium attitude, the station is in an orientation with the inertial principal axes nearly aligned with the local vertical and horizontal such that the station truss is near the direction of flight and the solar arrays are alternately nearly in the orbit plane or nearly perpendicular to the orbit plane, depending on the position of the Sun relative to the orbit plane. Table 3 describes the station attitude offset angles relative to the

Table 3.—Space station flight orientation offset angles.

Definitions: 1. Angle Between Y-Axis (Truss) and Velocity Vector 2. Angle Between Z-Axis (Solar Arrays) and Orbit Plane 3. Angle Between X-Axis (PV Radiators) and Orbit Perpendicular					
Flight Orientations	All	Near IOP		Near POP	
Offset Angle Number	1	2	3	2	3
Power Station With Orbiter	6.6	1.5	7.0	83.0	88.5
Power Station Without Orbiter	1.3	1.3	1.8	88.2	88.7
HTC With Orbiter (A-1)	7.4	11.6	13.8	76.2	78.4
HTC With Orbiter (A-2)	43.9	21.7	27.9	62.1	68.3
HTC Without Orbiter	5.4	0.3	0.7	89.3	89.7
IHTC With Orbiter (A-1)	24.0	44.2	49.8	40.2	45.8
IHTC With Orbiter (A-2)	14.3	16.5	16.8	73.2	73.5
IHTC Without Orbiter	2.7	0.6	0.6	89.4	89.4
PHC With Orbiter (A-1)	7.8	34.2	34.9	55.1	55.8
PHC With Orbiter (A-2)	10.4	22.1	22.7	67.9	67.9
PHC Without Orbiter	2.4	9.8	10.0	80.0	80.2

HTC Human Tended Capability
 IHTC International Human Tended Capability
 IOP In-orbit plane
 LVLH Local vertical/local horizontal
 PHC Permanent Human Capability
 POP Perpendicular-to-orbit plane
 PV Photovoltaic

velocity vector and the orbit plane for the various configurations. The offset angles depend on the angle between the inertial principal axes and the station body (or geometric) axes. In the torque equilibrium attitude/combination flight mode, solar array shadowing is similar to the arrow/combination flight mode. With the array axis nearly perpendicular to the orbit plane and the truss near the velocity vector, array shading occurs when the station is within about 15 degrees of the orbital day/night terminators for the dual array and when the station is within about 53 degrees of the terminators for the triple array, assuming beta (the angle between the Sun and the orbit plane) equals zero degrees. For orientations having the array axis near the orbit plane, maximum shading occurs at the same parts of the orbit, but shading diminishes to zero when the beta angle (absolute value) is greater than 15 degrees for dual arrays or 53 degrees for triple arrays.

The actual flight orientation will be a torque equilibrium attitude that reduces momentum buildup to a level that can be handled by the control moment gyros without violating other user and subsystem requirements. The ideal torque equilibrium attitude would result in extremely small momentum storage requirements. Unfortunately, this would induce unacceptable microgravity levels and cause large swings in the space station attitude during each orbit. Since microgravity, pointing, structural, and control requirements place constraints on the type of momentum management schemes that can be used, there are substantial cyclic momentum management requirements. For Option A-1, this cyclic momentum can be managed with some margin by Bus-1 if all six control moment gyros are operational. If one control moment gyro fails, the available momentum envelope shrinks. For some buildup stages, the required momentum peaks at this reduced momentum capability, providing little margin before performance is degraded. Option A-2 has more momentum storage capability than Option A-1, therefore no momentum management problems are anticipated even if a control moment gyro fails.

The torque equilibrium attitude/combination flight mode allows very good celestial and Earth pointing. Instruments without pointing gimbals could be attached to the station to obtain favorable viewing conditions for 73 percent of the time, when the station is oriented with the solar arrays nearly perpendicular to the orbit plane. The microgravity environment allows relatively constant conditions except during the periodic station reorientation maneuvers which occur about every 8 to 56 days.

Propellant Utilization

Reboost Requirements

Space station orbit decay due to the atmospheric drag can vary greatly as the solar activity goes through its 11-year cycle, and is also a function of many other factors such as time of day, time of year, and latitude. The aerodynamic forces and moments acting on the station in low-Earth orbit are strongly influenced by the solar arrays. The aerodynamic drag can be reduced by "feathering" the solar arrays during umbra passage or during times when power requirements are low and array cosine losses have minimal impacts. Solar array feathering is achieved by rotation of the solar arrays such that they are edge-on to the velocity vector.

The scenario for performing periodic reboosts assumes that the station is reboosted immediately after the end of each assembly mission to the appropriate altitude (225–235 nautical miles) that will allow the station to decay back to the rendezvous altitude of 220 nautical miles for the next flight. These reboost intervals and altitudes, using Option A-1 as an example, are shown in Figure 12. This philosophy utilizes the idea that being at a higher average altitude decreases the drag, decreases the orbit decay rate, and decreases the associated propellant required for reboosting. The reboost scenario during station assembly at the 28.8 degree orbit inclination requires approximately 40 percent less propellant than the 51.6 degree inclination. The performance of the shuttle at 28.8 degrees allows all missions to reach 220 nautical miles. At the 51.6 degree inclination, some assembly flights may be limited to 170 nautical miles due to the reduced shuttle performance at higher inclinations. The reboost frequency in the Permanent Human Capability phase is assumed to be 90 days, which is the same interval used for Space Station *Freedom*.

Propellant Utilization Budget

The complete propellant budget for reboost, attitude control, and momentum management is summarized in Table 4. This table lists the propellant required to complete each phase of the station assembly and an estimated yearly propellant requirement.

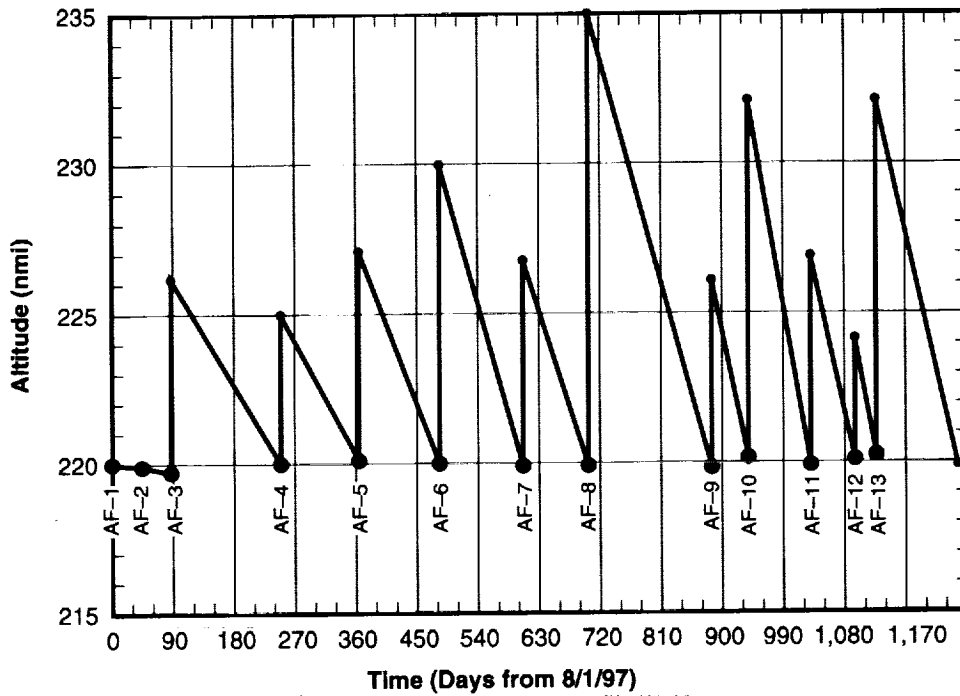

AF Assembly flight
nmi Nautical miles

Figure 12.—Option A-1 altitude time history.

Table 4.—Propellant utilization budget.

Option A-1 Propellant Budget

Function	Power Station	Human Tended Capability	International Human Tended Capability	Permanent Human Capability (PHC) (Yearly Req.)
Momentum Management	144 lb	607 lb	8,848 lb	2,341 lb
Reboost	220 lb	680 lb	3,835 lb	5,085 lb
Attitude Control	71 lb	121 lb	503 lb	364 lb
Total Per Phase (Number of Days)	435 lb (248)	1,408 lb (172)	13,186 lb (506)	7,790 lb (365)

- Bus-1 contains 11,660 lb of bi-propellant
- Attitude control system average $I_{sp} = 280$ sec
- Reboost average $I_{sp} = 300$ sec
- Flight schedule as of 5/14/93
- Altitude 220 nautical miles, 2σ atmosphere

Grand Total 22,819 lb
PHC + 1 year

Option A-2 Propellant Budget

Function	Power Station	Human Tended Capability	International Human Tended Capability	Permanent Human Capability (PHC) (Yearly Req.)
Momentum Management	46 lb	246 lb	3,605 lb	953 lb
Reboost	425 lb	880 lb	4,900 lb	6,395 lb
Attitude Control	129 lb	109 lb	2,062 lb	880 lb
Total Per Phase (Number of Days)	600 lb (248)	1,235 lb (172)	10,567 lb (506)	8,228 lb (365)

- Space station propulsion module contains 6,600 lb of mono-propellant per module, average $I_{sp} = 230$ sec
- Flight schedule as of 5/14/93
- Altitude 220 nautical miles, 2σ atmosphere

Grand Total 20,630 lb
PHC + 1 year

Rendezvous Approach

The approach to rendezvous assumed for the redesigned space station is identical to the Space Station *Freedom* program. Prior to rendezvous, the station will be reoriented to an attitude with the truss perpendicular to the orbit plane. For Option A-1, the solar arrays will be perpendicular to the orbiter approach corridor, and for Option A-2, will be parallel to the orbiter approach corridor. The orbiter approach corridor to the station is the same as planned for Space Station *Freedom*, but with a little tighter margin of safety on Option A-1 because of the shortened distance between solar arrays. The opening between the solar arrays has been reduced from about 266 feet in Space Station *Freedom* to about 118 feet in Option A-1 and 144 feet in Option A-2. A preliminary assessment of orbiter plume loads was conducted by the Lewis Research Center, and this indicated a potential problem for Option A-2 at the Power Station phase and for Option A-1 at the Human Tended phase and beyond. Solutions are available with orbiter thruster modifications, and Option A costs include an allowance for such modifications. Other potential solutions have been identified and are being investigated which avoid the more costly thruster modifications.

Assembly Scenario

Assembly Flight Manifests

The assembly phase of the space station consists of assembly flights (including outfitting flights), logistics flights, and utilization flights. Some utilization flights include partial complements of logistics or other equipment, but each is mostly payload-related. The designations of flight types follows the convention used in the Space Station *Freedom* program. The primary content and weight of each assembly flight is shown in Table 5. The primary difference in the assembly scenario for Options A-1 and A-2 can be seen in the first two flights. For Option A-1, the propulsion system (Bus-1) is launched on assembly flight 1, with the power elements on the second flight. Option A-2 launches equivalent hardware, but in reverse order. Flights 3 and subsequent ones are basically the same for both options, except for control moment gyro launches. In Option A-1, control moment gyros are from the Bus-1 program and are launched with the Bus-1 on flight 1. In Option A-2, control moment gyros are from Space Station *Freedom* and launch on flight 3, with a backup control moment gyro on flight 5.

Table 5.—Option A assembly scenario, 28.8 degree inclination, 220 nautical mile altitude.

Assembly Flight	Components	Launch Weight, lb	
		Option A-1	Option A-2
1	Propulsion, Bus-1 (A-1)	36,289	
2	Truss and Power Equipment, Solar Array, Batteries (A-2)		39,600
3	Truss and Power Equipment, Solar Array, Batteries (A-1)* SSRMS, SSF Propulsion Modules (A-2)	32,078	38,095
	Truss, Thermal Control, and Avionics	33,847	36,047
Power Station			
4	U.S. Common Core/Lab	37,284	37,284
Human Tended Capability			
4A	MPLM, 11 Lab Racks, Payloads	37,800	37,800
5	Truss, Thermal Control (2nd Set), and SPDM	35,386	35,373
6	Truss, Power Equipment, and Solar Array (2nd Set)	32,855	37,104
7	Japanese Experiment Module	37,800	37,800
7A	MPLM, 10 JEM Racks, Cryo Tanks, Payloads	37,800	37,800
8	ESA Attached Pressurized Module (APM)	37,800	37,800
8A	MPLM, 11 APM Racks, Payloads	37,800	37,800
9	JEM EF, ELM PS, and ES	37,800	37,800
International Human Tended Capability			
10	Truss, Power Equipment, and Solar Array (3rd Set)	29,695	31,563
11	U.S. Common Module/Hab	37,541	37,541
12	Airlock and Closet Module	37,164	37,164
13	2 Assured Crew Return Vehicles (Russian Soyuz)	37,759	37,759
Permanent Human Capability			

APM Attached Pressurized Module
 ELMES Experiment Logistics Module Exposed Section
 ELMPS Experiment Logistics Module Pressurized Section
 ESA European Space Agency
 JEMEF Japanese Experiment Module Exposed Facility

lb Pounds
 MPLM Mini-Pressurized Logistics Module
 SPDM Special Purpose Dexterous Manipulator
 SSF Space Station *Freedom*
 SSRMS Space Station Remote Manipulator System

* SSRMS for Option A-1 launched on flight 4A

Option A Space Station Redesign

The weights are within the shuttle launch weight allocations of 39,700 pounds for the first flight and 37,800 pounds for flight 2 and subsequent flights to a 220 nautical mile, 28.8 degree inclination orbit, as shown in Figures 13 and 14. Since the first assembly flight of Option A-2 does not carry a propulsion system, the destination for flight 2 is not 220 nautical miles, but the decayed orbit of the flight 1 payload, which is 217 nautical miles. The propulsion module tanks on flight 2 are filled to take advantage of the higher performance at 217 nautical miles, resulting in a manifest weight of 38,095 pounds. Launches of the international payloads (flights 7, 8, and 9) will require some off-loading of racks or downsizing of the current modules to stay within the shuttle capability. Launch of the Common Module/Hab requires off-loading of some racks. All quoted launch weights include an 1,800 pound space station margin. A shuttle external airlock is included as part of the launch mass on flights 5 and subsequent ones. The 3,500 pound shuttle manager's reserve is maintained on all flights. Hardware weight contingencies include 5-10 percent on Space Station *Freedom* program elements and 20 percent on all new elements.

After establishing the Power Station, utilization flights are initiated that take advantage of the existing on-orbit station capability. The Canadian Space Station Remote Manipulator System is launched on an outfitting flight following assembly flight 4 for Option A-1, and on the second assembly flight in Option A-2. The Special Purpose Dexterous Manipulator is launched on assembly flight 5 for both options.

Composite cargo X-axis center of gravity locations have been determined for all assembly flights for Options A-1 and A-2. These center of gravity locations are within the shuttle forward and aft limits. Center of gravity locations for logistics flights after Permanent Human Capability have also been verified to be within orbiter limits.

Option A assembly buildup scenarios have also been compiled for the 51.6 degree inclination orbit. Shown in Table 6 is a candidate assembly scenario for Option A-1 at the 51.6 degree inclination. This table is based on the assumption that the shuttle aluminum lithium external tank is available and used for all assembly flights. Notice the adjustments in

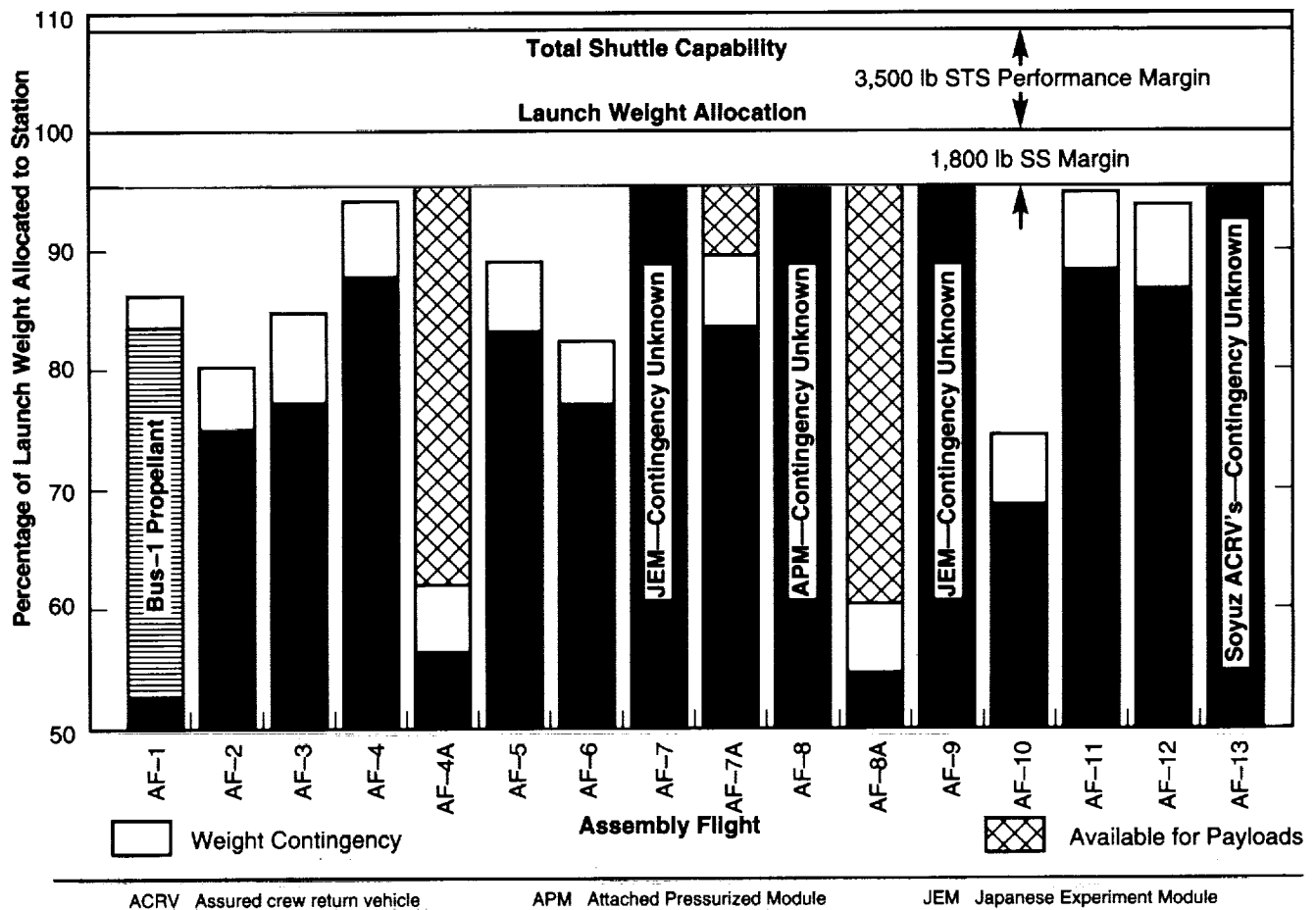

Figure 13.—Launch weights for station assembly sequence, Option A-1, 28.8 degree inclination, 220 nautical miles.

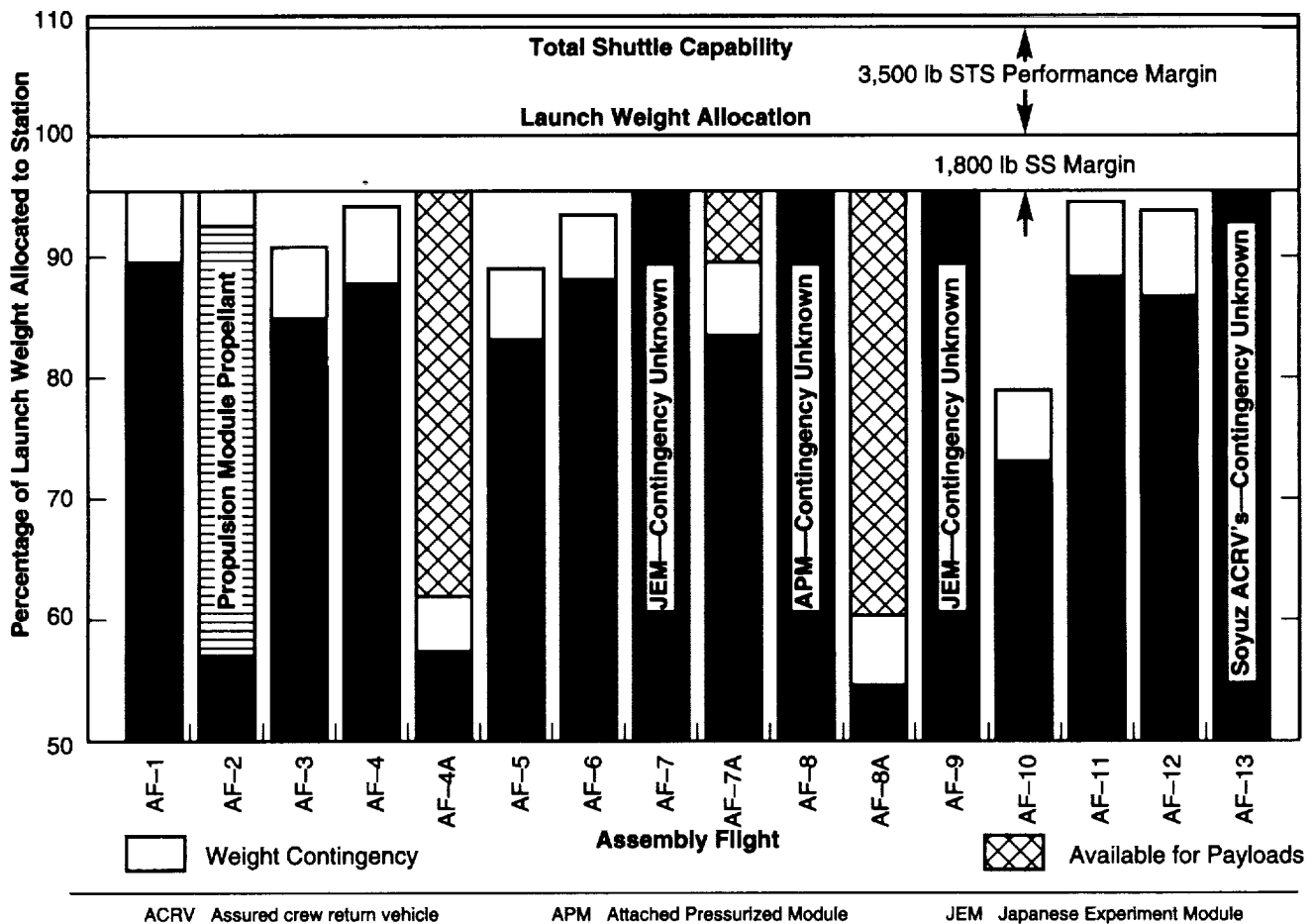

Figure 14.—Launch weights for station assembly sequence, Option A-2, 28.8 degree inclination, 220 nautical miles.

delivery altitude compared to the 28.8 degree inclination data, which is 220 nautical miles in Table 5. These lower assembly altitudes for the 51.6 degree option could be raised, but it would require additional off-loading or downsizing of the launch elements (1,000 pound off-loading per 10 nautical mile increase). This could result in remanifesting and additional assembly flights. The advanced solid rocket motor would be a substantial benefit in launching large modules, but is not considered available until early in the year 2001, after which it is an effective contribution to logistics.

Assembly Operations

For assembly flights prior to Human Tended Capability, the orbiter is berthed via the unpressurized berthing mechanism to the unpressurized berthing adapter located on the station truss. The orbiter is positioned in such a fashion to allow sufficient reach and free use of its manipulator arm. The space station elements brought up in the cargo bay are unloaded and positioned for attachment using the orbiter arm. Using currently designed hardware, crew extravehicular activity is required to complete the final attachment and the release of various hold-down mechanisms in preparation for deploying antennae, solar arrays, radiators, etc. At the

end of each flight, the unpressurized berthing mechanism is repositioned near the end of the new truss segment in preparation for the next flight. This is done by unlatching the unpressurized berthing mechanism from the truss, moving the truss with the Shuttle Remote Manipulator System, and relatching the unpressurized berthing mechanism in its new location.

After Human Tended Capability is reached, the orbiter docks at the lab to continue assembly. From this point on, the Canadian Mobile Servicing System is available for use. A typical scenario consists of the following activities: the new station element is removed from the cargo bay using the orbiter arm (Shuttle Remote Manipulator System) and handed off to the Space Station Remote Manipulator System; if the attachment location is within reach, the new element is installed at this time; if not, it is temporarily stowed on the truss via the Payload/Orbital Replacement Unit Accommodation mechanism; the Space Station Remote Manipulator System then moves to another location to gain proximity to the attachment point; the new element is then detached from the Payload/Orbital Replacement Unit Accommodation mechanism and positioned for attachment. A typical operations scenario is shown in Figure 15.

Table 6.—Option A-1 assembly scenario, 51.6 degree inclination, variable altitudes.

Assembly Flight	Components	Launch Weight, lb	Shuttle Lift Capability, lb	Assembly Altitude, nmi
1	Propulsion, Bus-1	36,289	37,000	194
2	Truss, Power Equipment, Solar Array, and Batteries	32,078	35,200	193
3	Truss, Thermal Control, and Avionics	33,847	35,200	193
Power Station				
4	U.S. Common Core/Lab	37,284	37,500	170
Human Tended Capability				
4A	MPLM, 11 Lab Racks, SSRMS, Payloads	34,500	35,200	193
5	Truss, Thermal Control (2nd Set), and SPDM	35,386	35,500	190
6	Truss, Power Equipment, and Solar Array (2nd Set)	32,855	34,500	200
7	Japanese Experiment Module (JEM)	37,500	37,500	170
7A	MPLM, 8 Racks, Cryo Tanks	34,500	35,800	187
8	ESA Attached Pressurized Module (APM)	37,500	37,500	170
8A	MPLM, 11 Racks, Payloads	34,500	35,900	186
9	JEM EF, ELM PS, and ES	37,500	37,500	170
International Human Tended Capability				
10	Truss, Power Equipment, and Solar Array (3rd Set)	29,695	36,200	183
11	U.S. Common Module/Hab	37,541	37,500	170
12	Airlock and Closet Module	37,164	37,500	170
N/A	Soyuz Not Launched on Shuttle			
Permanent Human Capability				

APM	Attached Pressurized Module	lb	Pounds
ELMPS/ES	Experiment Logistics Module Exposed Section	MPLM	Mini-Pressurized Logistics Module
ELMPS	Experiment Logistics Module Pressurized Section	nmi	Nautical miles
ESA	European Space Agency	SPDM	Special Purpose Dexterous Manipulator
JEMEF	Japanese Experiment Module Exposed Facility	SSRMS	Space Station Remote Manipulator System

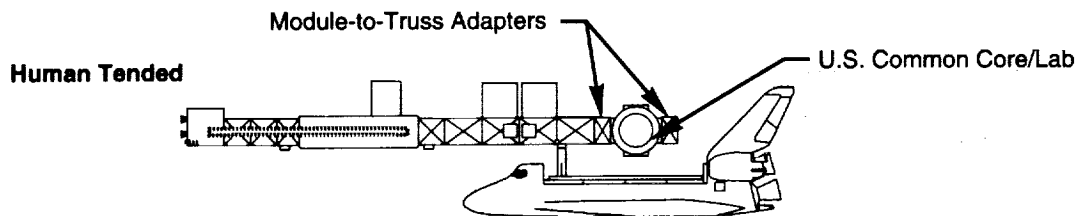

Requirements

- Rendezvous at 220 Nautical Miles
- Crew Size: 5
- Mission Duration: 7 days
- EVA Estimate:
 - 24 crew hours
- Flight Orientation:
 - Gravity Gradient (Orbiter's Tail to Earth, Belly Forward)
 - Orbiter Controls Attitude
- Integration Hardware:
 - 2 Remotely Operated Electrical Umbilicals (ROEU's)
 - Data Interface Unit
 - Grapple Fixture on Lab
 - Shuttle Remote Manipulator System

Major Operations

- Activate and Check Out Orbiter Interface (Data Interface Unit)
- Maneuver Station to Berthing Attitude
- Rendezvous and Berth to Power Station
- SRMS/EVA 1: Attach Starboard Module-to-Truss Adapter Structure to Lab
- Connect ROEU's to Unpressurized Berthing Adapter
- Unberth Lab and Mate to S1 Truss
- EVA 1: Connect S1 Truss to Lab Utilities
- Check Out Lab System (Ground)
- SRMS/EVA 2: Attach Port Module-to-Truss Adapter Structure to Lab
- Unmate Unpressurized Berthing Adapter to S1 Umbilicals
- Deploy Space Station
- Bring Unpressurized Berthing Adapter Home
- Reboost Space Station

Figure 15.—Option A-1 space station assembly flight 4 operations.

Typical deployment flights will require a crew size of 5, a mission duration of 7 days, and extravehicular activity times of up to 24 crew hours. The exception is flight 7, which will deploy the Japanese Experiment Module. It is estimated that this flight may require a mission duration of 12 days.

At the end of each flight (except flight 1 of Option A-2), the space station is left as a fully functional spacecraft with its own guidance, navigation, and control; the ability to change and maintain its orbit; maintain communication with the ground; and generate its own electrical power. If an interruption were to occur in the assembly flights, the space station would be able to safely remain in orbit for an extended period. The only exception to this is the first flight of Option A-2. On this flight the first element is left in a completely passive mode and will decay from orbit in three to five years if not further assembled.

Assembly Operations Assessment

The primary differences from Space Station *Freedom* in the assembly of Option A is fewer total flights, absence of the Mobile Transporter, and the interposition of the Common Core/Lab between truss segments. As shown in Table 7, the fewer number of flights leads to a significant reduction in total extravehicular activity. This option consists of fewer elements that require integration in orbit.

The assembly of the Power Station is very similar in concept to early flights of Space Station *Freedom*. The major difference is that the unpressurized berthing adapter must be unlatched and relatched at a new location on the truss using the Shuttle Remote Manipulator System instead of riding on the Mobile Transporter to a new location.

Table 7.—Extravehicular activities required for assembly.

Space Station <i>Freedom</i> Design			A-1 Design			A-2 Design		
SSF Mission Build Flights	Number of EVA's Required	EVA Time (Crew Hours)	A-1 Redesign Assembly Flights	Number of EVA's Required	EVA Time (Crew Hours)	A-2 Redesign Assembly Flights	Number of EVA's Required	EVA Time (Crew Hours)
MB-1	2	23	AF-1	0	0	AF-1	2	16
MB-2	2	21	AF-2	2	24	AF-2	2	16
MB-3	2	22	AF-3 (PS)	2	16	AF-3 (PS)	2	24
MB-4	2	22	AF-4 (HTC)	2	24	AF-4 (HTC)	2	24
MB-5	3	30	AF-4A	1	12	AF-4A	0	0
MB-6 (MTC)	2	19	AF-5	1	12	AF-5	1	12
MB-6A	2	13	AF-6	2	24	AF-6	2	24
MB-7	2	16	AF-7	2	24	AF-7	2	24
MB-8	2	21	AF-7A	0	0	AF-7A	0	0
MB-9	1	10	AF-8	1	6	AF-8	1	6
MB-10	2	27	AF-8A	0	0	AF-8A	0	0
MB-11	2	17	AF-9 (IHTC)	1	12	AF-9 (IHTC)	1	12
MB-12	3	32	AF-10	2	24	AF-10	2	24
MB-13	2	24	AF-11	2	24	AF-11	2	24
MB-14	2	24	AF-12	2	16	AF-12	2	16
MB-15	1	12	AF-13 (PHC)	1	6	AF-13 (PHC)	1	6
MB-16	2	24						
MB-17 (PMC)	2	24						
Summary								
			Total Mission Build Flights		Total Number of EVA's		Total EVA Crew Hours	
	SSF Design		18		36		381	
	A-1 Design		16		21		224	
	A-2 Design		16		22		228	

EVA Extravehicular Activity

HTC Human Tended Capability

IHTC International Human Tended Capability

MTC Man Tended Capability

PHC Permanent Human Capability

PMC Permanently Manned Capability

PS Power Station

SSF Space Station *Freedom*

The physical attachment of the Common Core/Lab to the truss, although different from Space Station *Freedom*, appears feasible. This operation will be done with the Shuttle Remote Manipulator System. The movement of this element from the cargo bay to its attachment location maintains adequate clearances and lies within the physical capabilities of the Shuttle Remote Manipulator System.

The Canadian Mobile Servicing System is installed and checked out for station buildup beyond Human Tended Capability. Assembly elements are removed from the cargo bay using the Shuttle Remote Manipulator System and handed off to the Space Station Remote Manipulator System for final repositioning and attachment as in the Space Station *Freedom* program. If the final attachment location exceeds the reach of the Space Station Remote Manipulator System, the provision has been made for temporarily fixing the new element to the truss, moving the arm to a new location and picking the element back up. This added operation is due to the deletion of the Mobile Transporter and adds to the assembly time, but is feasible.

Systems/Subsystems

Bus-1 System Description

The Bus-1 spacecraft (Figure 16) was developed by Lockheed Missiles and Space Company, and provides an integrated system to position and control an attached payload. The basic (unmodified) Bus-1 subsystems are described as follows.

Bus-1 guidance, navigation, and control are provided by an attitude reference system that senses deviations from a desired attitude and position. This information is processed within the data management system and acted on by a set of effectors. The attitude reference system contains nine rate gyros, three star sensors, two 3-axis magnetometers and nine sun sensors. The effectors consist of six single-axis gimballed control moment gyros, each rated at 1,700 foot-pound-seconds of angular momentum. In addition, 12 reaction control jets are used to assist the control moment gyros.

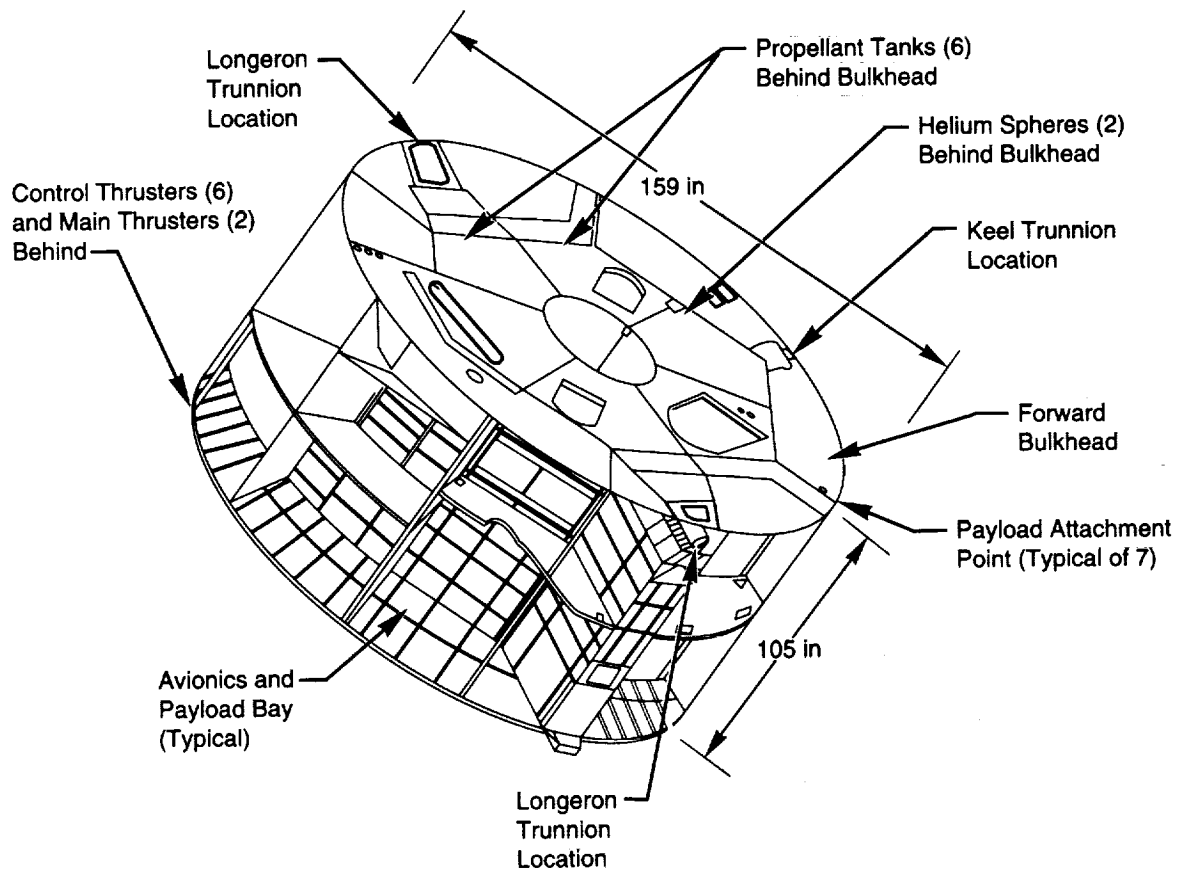

Figure 16.—Bus-1 guidance, navigation, control, and propulsion system (skin panels, avionics, and deployables not shown).

Bus-1 contains 11,660 pounds of nitrogen tetroxide and monomethylhydrazine propellants. The propulsion system is totally contained within Bus-1 and consists of four pressurization and six propellant tanks feeding six pairs of 14-pound thrusters (Aerojet AJ10-220) and two 200-pound reboost engines (Marquardt R42). The attitude control engines are positioned circumferentially around the aft end of Bus-1. This provides the station with the capacity to rotate about its principal axes. The reboost motors provide translational capacity. To prevent an inadvertent thruster firing, the propulsion system has redundant failure tolerant valve sequencing and avionics hardware. There are provisions to change out Buses as required, without loss of attitude control. Although not yet matured, several concepts are being investigated to resupply the Bus-1 propulsion system with propellant transferred from the orbiter's orbital maneuvering system tanks.

The power system supplies an average of 2.6 kilowatts—1.8 kilowatts for Bus-1 active systems and 0.8 kilowatts for the payload. For power generation, a fixed solar array of gallium arsenide/germanium cells, rated at 5 kilowatts maximum output, is mounted to the payload structure; the array could be mounted on the S5 interface structure for space station. For power storage, six 90 amp-hour nickel-hydrogen batteries are mounted inside Bus-1. Heat pipes are used for battery thermal control.

The data management system is composed of primary and secondary processors, both with A and B strings providing some internal redundancy, and hardwired attitude control logic for backup control. The command and control computer operates at 1.4 million instructions per second with 96 kilobytes of 24 bit word addressable memory. The system can store a maximum of 12,000 commands. A 100 channel serial input/output processor and a remote decoder multiplexer are also part of the data management system.

The communications system consists of a dual channel S-Band transponder capable of 1 kbps on the uplink and 2 or 32 kbps for downlink, with 4 switchable antennas. The system is compatible with the Spacecraft Ground Link System used by the U.S. Air Force. The S-Band system could be made compatible with the NASA Tracking and Data Relay Satellite System, but would then be limited to 16 kbps downlink. Primary communications are effected by a three axis antenna pointing system located on the aft bulkhead. The current primary Bus-1 communication electronics are not suitable for high rate Ku-Band Tracking and Data Relay Satellite System communications.

The structure is built around a central hexagonal core that acts as the primary load-carrying backbone. The six propellant tanks are located within this hexagonal core. Bulkheads and transverse partitions are placed around this core, creating bays for equipment mounting. Three sill trunnions and

one keel trunnion are located on the periphery for ground handling and to attach Bus-1 to the launch vehicle. While not specifically designed to meet the micrometeoroid and debris requirements, the structural configuration offers more inherent shielding than most other space station elements. According to preliminary analysis, the probability of no penetration for a standard Bus-1 flying in arrow mode is 0.9949. Payloads can be structurally attached to Bus-1 by a 110 inch bolt circle or 7 tab fittings spaced unevenly around the periphery. Bus-1 can support the cantilevered payload equivalent of 10 klbs at 40 inches from the forward bulkhead. Bus-1 will be mated to the station by the S5 interface structure, which will include power, data, and communications interfaces.

Although it has never flown on the shuttle, Bus-1 has successfully completed all three shuttle safety reviews. It has flown multiyear missions using expendable launch vehicles. The attitude/position reference system appears to meet or exceed current Space Station *Freedom* requirements. The reboost capability, as provided by the two main engines, is single-failure tolerant. The data management system is at least single-failure tolerant. Bus-1 has a health monitoring system with telemetry for fault analysis and an autonomous response to on-orbit faults.

The specified verification procedures and requirements used were compared to those in MIL-STD 1540B (test requirements for space vehicles), in spot checks of seven representative components (orbit adjust thruster, propulsion interface unit, computer assembly, gyro, reaction control thruster, main propellant tank, and pressurant tank). The various qualification tests from this analysis seem to meet or exceed the requirements of 1540B with, however, some differences in cycles and dwell times. Overall, Bus-1 hardware verification appears to be consistent with the intent of 1540B.

Bus-1 is existing, flight-proven hardware that can provide reboost and guidance, navigation, and control for the redesigned space station. With on-board power generation, thermal control, communication and data management, Bus-1 provides a self-sufficient spacecraft as an initial building block. Since Bus-1 is not designed for on-orbit maintenance and repair, it must be replaced as a system. Based on its demonstrated reliability and inherent redundancy, Bus-1 changeout will be driven by propellant depletion rather than system failure. Data provided by Lockheed Missiles and Space Company indicates that Bus-1 has operated for more than 40,000 hours on orbit without a mission-ending failure, as evaluated using space station mission success criteria.

Any modification to Bus-1 would be limited to "make it work" items. Modifications identified in this study are: reaction control thruster repositioning and modification to

ensure two-failure tolerant reboost capability; addition of a mechanical adjustment to allow the orbit adjust thrusters to track the station center of gravity; solar array relocation; addition of an electrical converter, communication and mechanical interfaces, thermal closeout, and power/data grapple fixtures; software changes; and modification of the Safe Hold Mode. An add-on communications system is being assessed for the potential to perform the communications and tracking function for the station. At this point, Bus-1 appears to have good potential for replacing the Space Station *Freedom* propulsion and attitude control functions with a single piece of existing, self-sufficient, flight-proven equipment. However, more detailed analyses remain to be performed, such as full determination of the attitude control margins associated with Bus-1 control moment gyros, an effective Bus-1 changeout strategy, and detailed costing.

Guidance, Navigation, and Control Subsystem

Requirements

The guidance, navigation, and control subsystem controls the attitude and orbit of the space station. In addition, the guidance, navigation, and control subsystem provides position and attitude information to space station users, as well as other space station subsystems such as power and thermal control. These requirements are the same as for Space Station *Freedom*.

Hardware Functional Description

Although the actual hardware used varies from Option A-1 to Option A-2, the types of hardware required and their functions remain somewhat constant. Block diagrams of the Option A-1 and A-2 guidance, navigation, and control systems are shown in Figures 17 and 18.

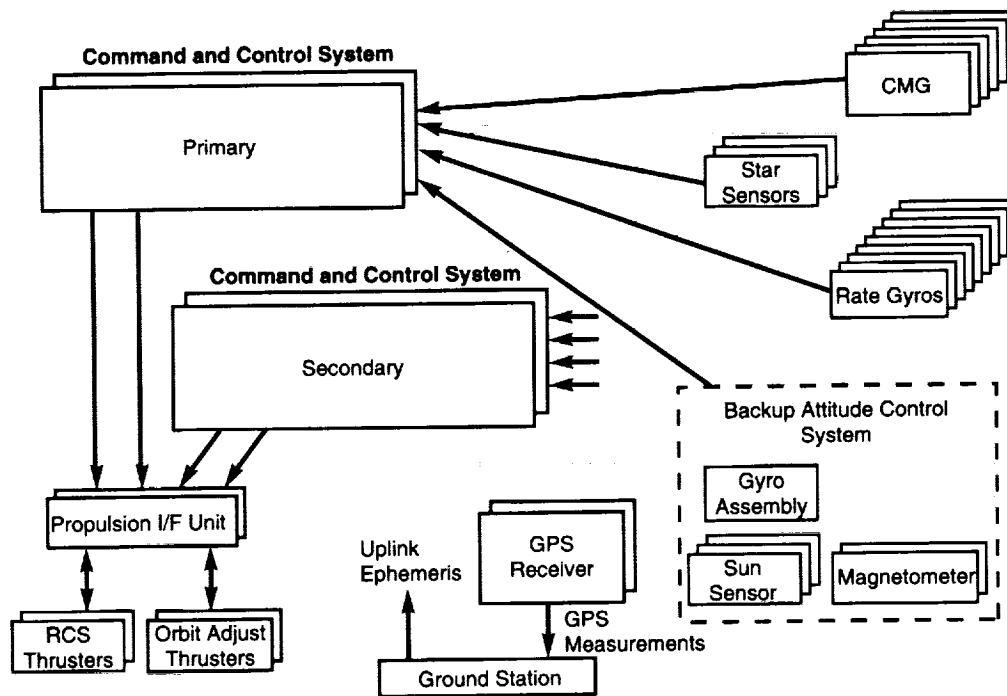

- Active guidance, navigation, and control after first flight; requires no passive dampers
- Six single-gimbal CMG's
 - 1,700 ft-lb-sec momentum storage each
 - High-torque capability
 - 353 lb each
- Twelve 14 lbf RCS thrusters
- Two 250 lbf reboost thrusters

CMG	Control Moment Gyro
GPS	Global Position System
ft-lb-sec	Foot pounds per second
I/F	Interface
lb	Pound(s)
lbf	Pound-force
RCS	Reaction Control System

Figure 17.—Option A-1 (with Bus-1) guidance, navigation, and control subsystem.

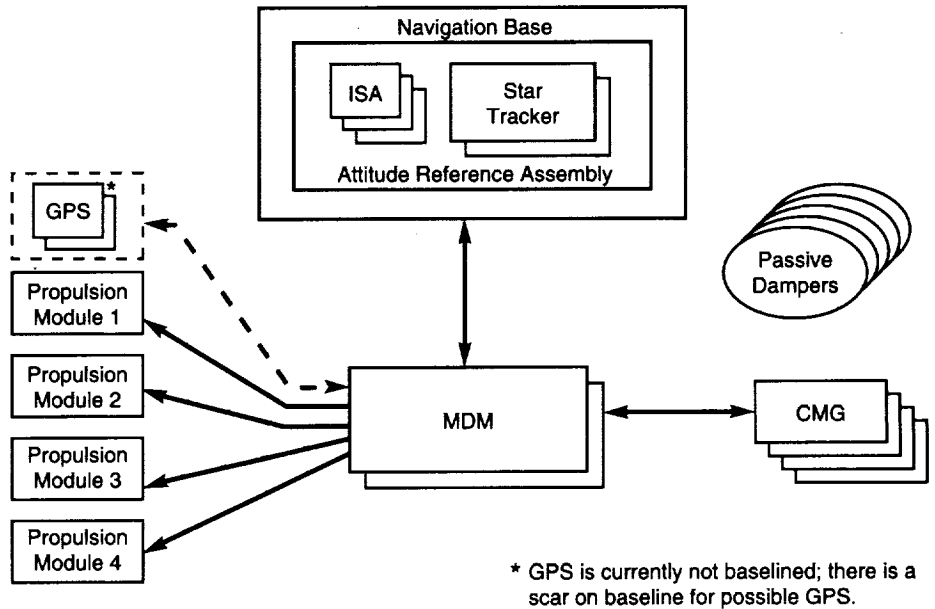

- Guidance, navigation, and control elements are same as Space Station *Freedom*.

GMG Control Moment Gyro
GPS Global Position System

ISA Inertial Sensor Assembly
MDM Multiplexer/Demultiplexer

Figure 18.—Option A-2 guidance, navigation, and control subsystem.

Space station attitudes and attitude rates are measured by two different assemblies. The inertial sensor assembly consists of gyros that measure the three-axis inertial rates for stabilization purposes and as a backup to the star sensor inertial attitude reference. Inertial attitudes are determined by either star scanners (A-1) or star trackers (A-2). Either type measures the position and magnitude of stars, which can be compared to a catalog of known stars to determine inertial attitude.

The control system affects space station attitude changes through either the attitude control system thrusters or the control moment gyros. The control moment gyros provide the primary attitude control because they do not in themselves use propellant and because fine control (low microgravity) can be achieved. The control moment gyros' capability will be exceeded periodically (reach maximum momentum storage capability) for some configuration/orientation combinations, and must be desaturated. The thrusters are used to desaturate the control moment gyros and also for certain large-angle attitude changes (reorientation to a completely new attitude). In addition, on Option A-2 only, the thrusters (or passive magnetic dampers) are used for primary attitude control during the early buildup phases when the control moment gyros are not operational.

Navigation (determining the position of the station in space) is handled differently for the two options. Option A-1 uses a global positioning system receiver. Position information is received from global positioning system satellites already on orbit and relayed to the ground, where the position is calculated and sent back up to the space station. Option A-2 uses radar systems on the ground to track and directly locate the space station. The space station position is then relayed up to the space station.

Software Functional Descriptions

The guidance, navigation, and control software manages the guidance, navigation, and control hardware and selects the guidance, navigation, and control mode based on commands from the ground and on internal management logic. Each of the following software functions is directly related to meeting requirements levied on the guidance, navigation, and control subsystem.

The navigation function accepts position data from the ground and predicts the space station position until the next update from the ground. The guidance function implements reboost maneuvers in response to ground-supplied thruster burn times and attitudes. The attitude determination function

determines and maintains the attitude and angular rate knowledge of the space station. The pointing and support function provides pointing data to users and other space station systems (see Interfaces section below). The maneuver control function maintains the attitude and stability of the space station within prescribed limits. Under normal operations, the space station attitude is maintained at a torque equilibrium attitude to delay control moment gyro saturation as long as possible.

Interfaces

The guidance, navigation, and control subsystem maintains many interfaces, both with other space station systems and with the users. The guidance, navigation, and control standard interface consists of the state vector (position and velocity, attitude, and attitude rates), an indicator of the state vector quality, a vector that points to the Sun, solar eclipse times, and times when radio communication to the ground is made or lost. The users of this standard interface include the thermal control system, communications and tracking, the Japanese Experiment Module, payloads, the electrical power system, and the orbiter. In addition to these standard interfaces, special interfaces are maintained with the data management system, ground control, the Japanese Experiment Module moving payload (Japanese Experiment Module Remote Manipulator System), and the propulsion system.

Space Station Resources Used by Guidance, Navigation, and Control

For Option A-1, all guidance, navigation, and control components are contained within the Bus-1. For Option A-2, the resources used are: 1,057 watts of electrical power. The complete A-2 guidance, navigation, and control system mass is 2,830 pounds.

Propulsion System

The Bus-1 propulsion system, used in Option A-1, is described in section II.E.1. Although not yet matured, several concepts are being investigated to resupply the Bus-1 propulsion system with propellant transferred from the orbiter's orbital maneuvering system tanks.

The propulsion module for Option A-2 is identical to the Space Station *Freedom* propulsion system. There are two replaceable propulsion modules at the Power Station and Human Tended Capability phases, and four propulsion modules at the International Human Tended Capability and Permanent Human Capability phases. Each propulsion module weighs 11,300 pounds, including 6,800 pounds of hydrazine. There are ten 25 pound attitude control thrusters and three 55 pound reboost motors on each module. These engines are configured to allow the station to translate and orient in all directions and attitudes (six degrees of freedom). The propulsion module has three levels of inhibits,

redundant failure tolerant valve sequencing, and avionics hardware to prevent inadvertent thruster firing. When the propellant in the propulsion module is depleted, the entire module is replaced and returned from orbit for propellant resupply and reuse.

An integral propulsion module concept was developed for one-time use during the assembly of the space station at an inclination of 51.6 degrees. This integral propulsion module uses the same hardware as the baseline propulsion module, but it is integrated inside the S3 truss structure.

Electrical Power System

The electrical power system for Option A maintains the basic solar array/battery concept used on Space Station *Freedom*. The exception to that design was the elimination of the alpha joint and the modification of the electrical power system's primary distribution architecture. The modular buildup approach of electrical power generation is maintained through the utilization of the *Freedom* Work Package 4 photovoltaic module. Each module provides a 20 kilowatt electric power generation increment. Using this concept, electrical power system growth potential is maintained through all space station phases.

Alpha joints (as used on *Freedom*) have been deleted and the beta joints on the photovoltaic module are used for orbit solar tracking. Compensation for seasonal solar angle (beta angle) losses are minimized by an orientation maneuver at the optimum beta angle. The solar arrays are oriented perpendicular to the orbit plane for beta angles between -23 and +37 degrees and are flown in the orbit plane for other beta angles. The yearly orbit average power reduction of approximately 7 to 8 percent by the alpha joint deletion is justified by the reduced mass, cost, operational complexity, and improved reliability. The mode with arrays in the orbit plane is required only 28 percent of the year and allows periods of up to 59 days to occur between required maneuvers. Two 100-day periods per year can also be obtained between maneuvers at the expense of minimal power reduction.

The revised electrical power system architecture is shown in Figure 19. These changes resulted in overall electrical power system efficiency improvements and enabled a two-failure tolerant system at earlier space station buildup phases. The architecture changes reduced the mass and the thermal rejection requirements 2.7 kilowatts (thermal) per photovoltaic module.

Electrical power available at each space station buildup phase is shown in Table 8 for both Option A-1 and Option A-2. The data for the power values were generated by two approaches—yearly orbital average and representative orbital average. The values reflect the differences in the two approaches as well as in the analytical models (i.e., array shadowing, system efficiencies, orientations, etc.) Both sets

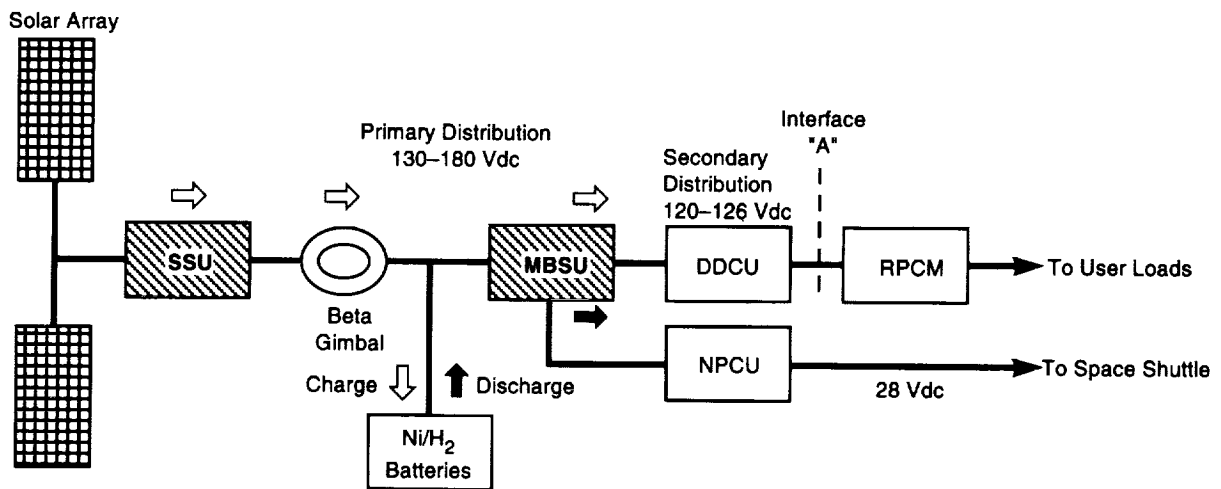

SSU Sequential Shunt Unit
 MBSU Main Bus Switching Unit
 DDCU DC-to-DC Converter Unit
 NPCU NSTS Power Converter Unit
 RPCM Remote Power Controller Module
 Ni/H₂ Nickel Hydrogen
 Vdc Volts direct current

Notes:

Orbital Data	Max.	Min.
☞ Sunlit	64	57
➡ Eclipse	36	29

Redesigned or new in modified power distribution system

- Beta gimbal used for orbit tracking
- Shaded blocks indicate modified hardware

Figure 19.—Electrical power system, modified distribution system.

Table 8.—Electrical power system configuration for Options A-1 and A-2.

**Non-Torque Equilibrium Mode/Inclination = 28.8 Degrees, Power Budget (kW_e)
 (All calculations include solar array shadowing)**

Flight Phase	Power Station	Human Tended Capability		International Human Tended Capability		Permanent Human Capability
	With Orbiter	Without Orbiter	With Orbiter	Without Orbiter	With Orbiter	Without Orbiter
Representative * Orbital Average (kW)	23.1/23.1	23.1/23.1	23.1/23.1	46.1/46.1	46.1/46.1	57.0/57.0
Yearly Orbital Average ** Power @ Interface "A" (kW yr/yr)	24.4/24.4	24.4/24.4	24.4/24.4	48.0/48.0	48.0/48.0	64.0/64.0
Housekeeping						
• U.S. Basic Subsystems ^{1,2}	14.3/14.1	6.7/6.9	16.2/16.5	8.3/9.7	17.7/19.3	13.4/14.8
• Other Elements ³	—	—	—	—	—	2.2/2.2
• Internationals ⁴	—	—	—	10.4/10.4	10.4/10.4	10.4/10.4
Available for User (Orbital Ave.)	8.8/9.0	16.4/16.2	7.0/6.6	27.4/26.0	18.0/16.4	31.0/30.0
(Yearly Ave.)	10.1/10.3	17.7/17.5	8.2/7.9	29.3/27.9	19.9/18.3	38.0/36.6
Spacelab Users (max)	3.4/3.4					

Notes:

- 1 Includes Subsystems, Orbiter, and Spacelab
 - 2 Orbiter With 4 Cryo Tank Sets, 8 kW, 20-day stay
 - 3 Includes Assured Crew Return Vehicle, Cupola, Closet Module, and Airlock
 - 4 Canadian Space Agency (1.43 kW), European Space Agency (3.74 kW), and NASDA (Japan) (5.22 kW)
- * Lewis Research Center calculated value for average eclipse day at beta angle of 27° and vehicle flying in Z/POP orientation.
 ** Derived from Lewis Research Center-supplied data.

Option A Space Station Redesign

of data are shown in Table 8 with the yearly orbital average being the basis for analysis of all associated data in this report. The representative orbital average data, as used in the *Space Station Redesign Team Final Report to the Advisory Committee on the Redesign of the Space Station*, are derived from the analysis of a typical orbit on a day having an average solar eclipse period.

Housekeeping power includes station subsystems, assured crew return vehicles (2), cupola, Closet Module, airlock, orbiter/Spacelab, and the international partners' elements. The power available for payload users is shown for the yearly orbital average condition. At Permanent Human Capability, the power to the users exceeds 35 kilowatts for both Option A-1 and Option A-2. For the two human-tended phases, electrical power is shown with and without

the orbiter attached to the station. A further breakout of the housekeeping power for the United States systems at the Permanent Human Capability phase is shown in Table 9 for both Options A-1 and A-2, as well as, a comparison to Space Station *Freedom*. Performance on a specific day may vary due to attitude and/or time of year, a typical example is shown in Figure 20.

The interface to the international users is maintained as defined for Space Station *Freedom*. Power is provided to Bus-1 after flight 3 and to the orbiter as required through the Power Station, Human Tended Capability, and International Human Tended Capability buildup phases. Power is not required by the orbiter at Permanent Human Capability. Spacelab power requirements are also provided to the orbiter during the Power Station mission phase.

Table 9.—Option A subsystems power summary at Permanent Human Capability, without orbiter, U.S. elements/systems only.

United States Systems	Housekeeping Power (kW) Yearly Orbital Average		
	SSF	Option A-1	Option A-2
Data Management and Applications S/W	3.48	1.82	2.12
Electrical Power Generation	0	0	0
Power Distribution and Control	1.48	0.91	1.07
Communications and Tracking	1.06	1.23	1.23
Environmental Control and Life Support	5.41	3.66	3.66
Thermal Control	1.70	1.98	1.98
Crew Health Care	0.32	0	0
Crew Equipment (Crew Systems)	1.43	1.48	1.48
Propulsion	0.90	0.29	1.24
Structures (Primary and Secondary)	0	0	0
Mechanical Systems	0.20	0.10	0.10
Guidance, Navigation, and Control	0.53	0	1.01
Extravehicular Activity	0.01	0	0
Utilities	0	0	0
Consumables	0	0	0
Miscellaneous	0	0.22	0.22
Margin	0.79	0.58	0.70
Bus-1 (Option A-1)	0	1.11	0
Total	17.31	13.38	14.81

kW kilowatts

SSF Space Station *Freedom*

S/W software

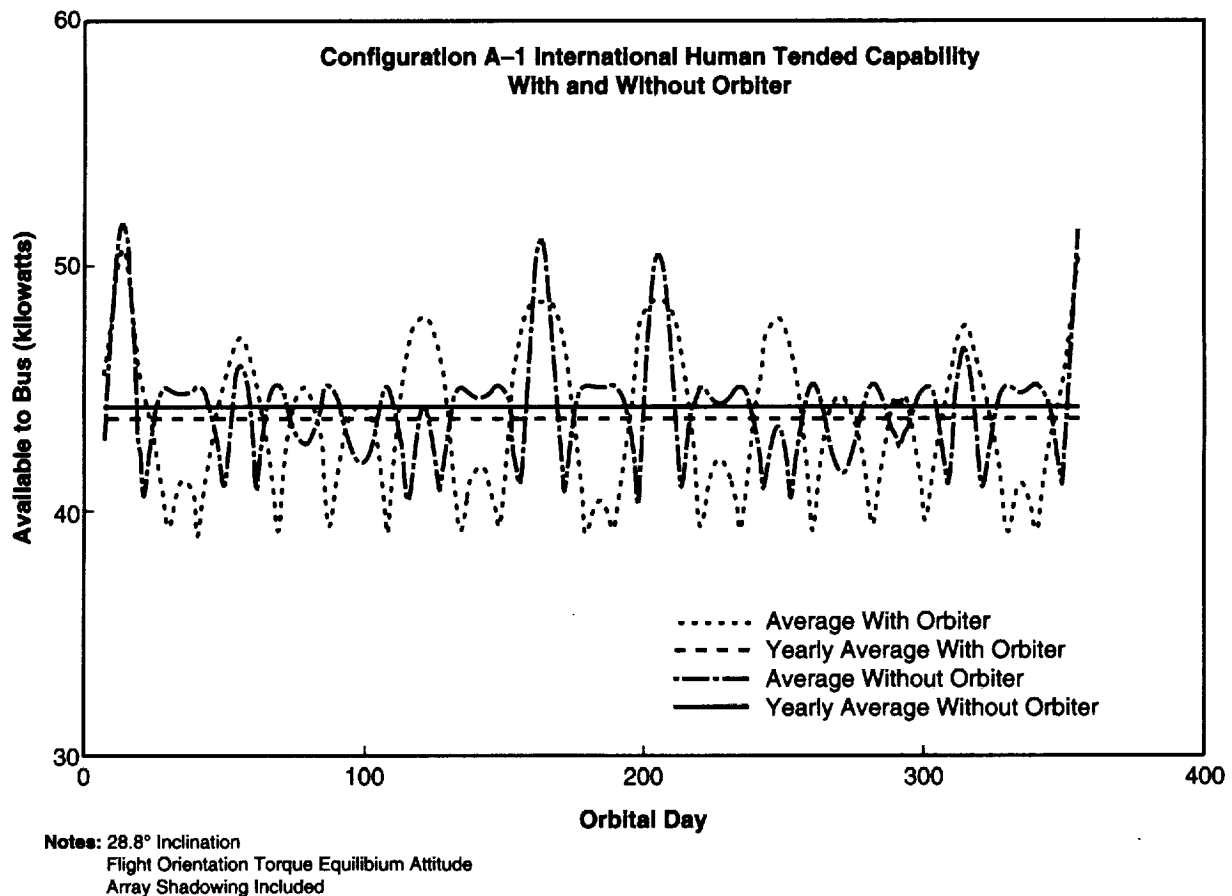

Figure 20.—Available power example.

Thermal Control System

The Option A thermal control system collects, transports, and rejects waste heat and maintains structures, systems, and subsystems within their required temperature limits using active and passive approaches. The active system (Figure 21) consists of a photovoltaic system mounted on each photovoltaic truss segment, an external central system mounted on the central truss segments, and a module internal thermal control system. The photovoltaic and the central external systems utilize the Space Station *Freedom* photovoltaic thermal control design; a single phase ammonia system (as opposed to *Freedom's* two-phase ammonia central system) utilizing dual passage radiators, pumps, and controls to provide a redundant system. The central system consists of a moderate- and a low-temperature fluid loop that is cross-strapped to the initial photovoltaic loop to provide two-failure tolerance to critical loads during buildup. The Common Core/Lab module's internal thermal control system (Figure 22) utilizes single-phase water as the transport media in two loops, which are connected to the central system via heat exchangers on the module end cones. The moderate- and low-temperature loops are cross-strapped to provide redundancy for critical systems. This system also collects waste heat from the Mini-Pressurized Logistics Module and provides structural heating of the cupola.

The lab also supports the European Attached Pressurized Module and the Japanese Experiment Module via coolant connections to two additional sets of heat exchangers mounted externally on the lab. The Common Module/Hab has a similar system and provides coolant support for the airlock. These internal systems are identical to the Space Station *Freedom* internal thermal control system.

The modules, passive thermal control system and truss-mounted equipment utilize heaters, insulation, coatings, and isolators to maintain temperatures within required limits. Some truss-mounted equipment also uses passive radiators, louvers, and phase-change materials. Command and data management for both internal and external thermal control are provided by the onboard data management system.

Table 10 summarizes the system characteristics and capabilities. Failure tolerance is improved over the baseline *Freedom* design by modifying the central system to a design similar to the photovoltaic thermal control system. This also eliminates the development and verification of a second thermal control system. All of the system interfaces remain unchanged.

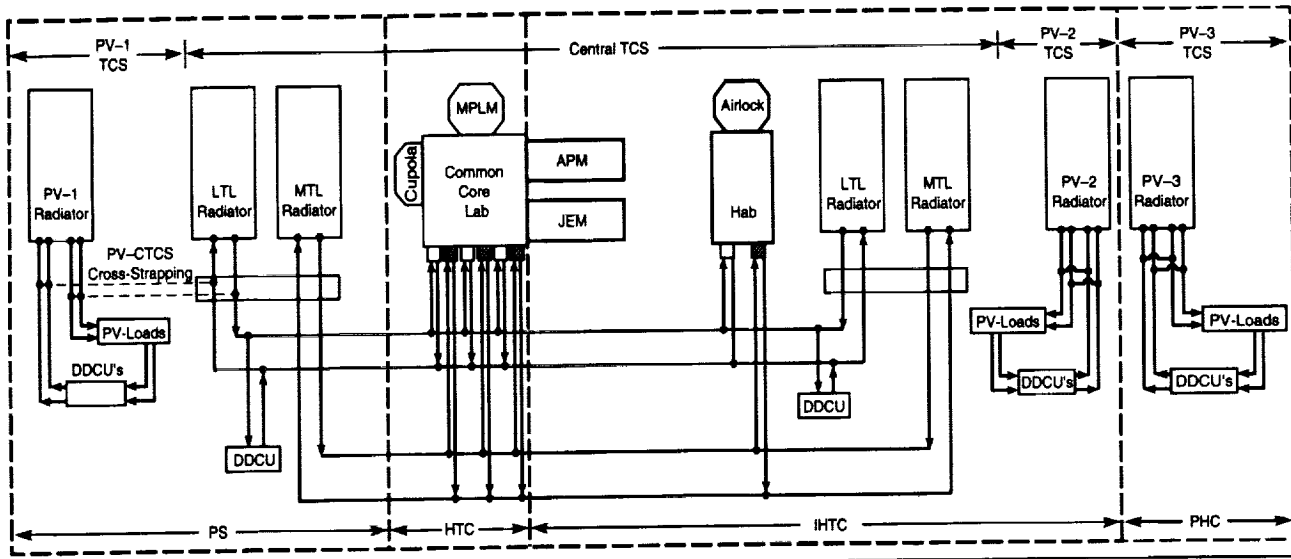

- | | | | | | |
|------|--------------------------------|------|-----------------------------------|--|--------------------|
| APM | Attached Pressurized Module | MTL | Moderate-temperature loop | | LTL Heat Exchanger |
| CTCS | Central thermal control system | MPLM | Mini-Pressurized Logistics Module | | MTL Heat Exchanger |
| DDCU | DC-to-DC conversion unit | PV | Photovoltaic | | |
| LTL | Low-temperature loop | TCS | Thermal control system | | |
| JEM | Japanese Experiment Module | | | | |

Figure 21.—External active thermal control system overview schematic.

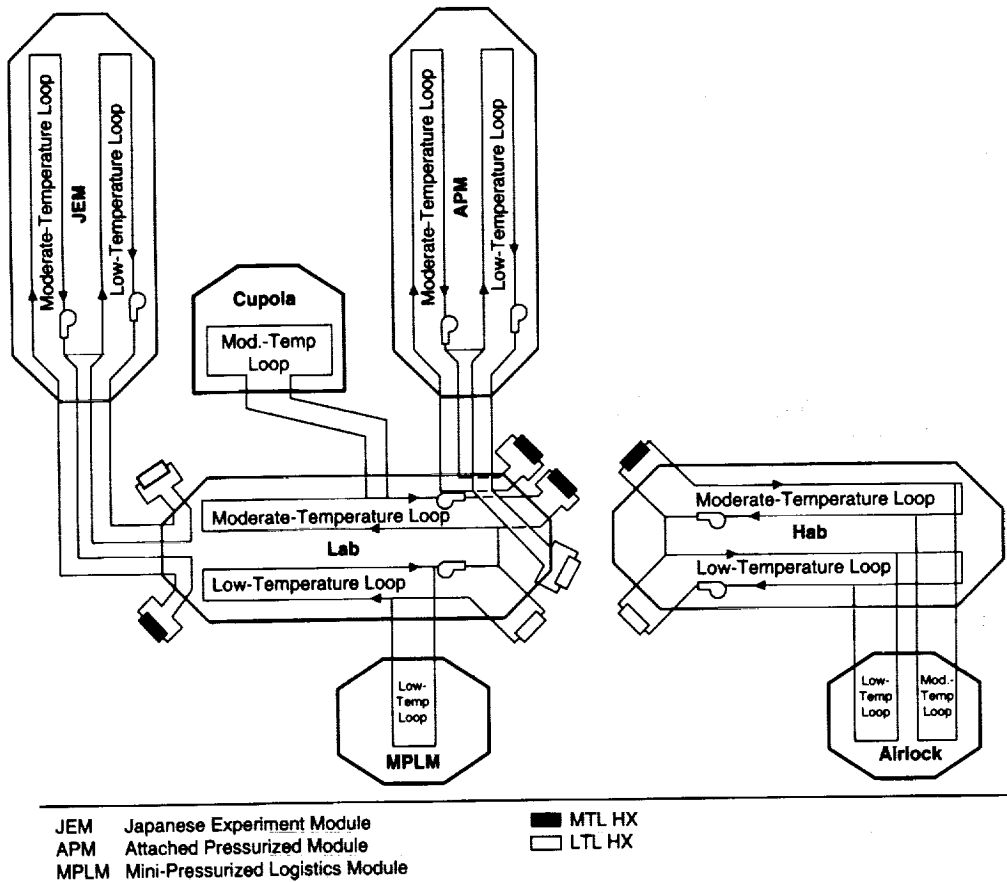

- | | | | |
|------|-----------------------------------|--|--------|
| JEM | Japanese Experiment Module | | MTL HX |
| APM | Attached Pressurized Module | | LTL HX |
| MPLM | Mini-Pressurized Logistics Module | | |

Figure 22.—Internal thermal control system overview schematic.

Table 10.—Space station thermal control system characteristics.

Photovoltaic Thermal Control System (PVTCS)			Central Thermal Control System (CTCS)		
<ul style="list-style-type: none"> Utilizes WP04 baseline single-phase ammonia PV-1: 2 independent loops—single-failure tolerant to 50% power PV-2,3: 2 cross-strapped loops—single-failure tolerant to 50% heat rejection PV TCS jumped to CTCS for two failure tolerance for station survival Deleted 6 BCDU's and 2 DCSU's <ul style="list-style-type: none"> Added 2 MBSU's 2.7 kW (36%) load reduction from baseline (7.4 kW) PFCS performance: <ul style="list-style-type: none"> Pump cap: 2,570 lb/hr @ 23.1 PSID and 1 °F Power: 265 W average Weight: 210 lb Radiator performance: Eight 2-sided panels 960 ft² rejects ~7.4 kW @ ~ 0 °F 			<ul style="list-style-type: none"> 6 WP02 two-phase ammonia radiators replaced by four WP04 single-phase radiators Two external temperature loops Central bus supports truss-mounted DDCU's and 14 kW and 25 kW heat exchangers mounted to lab end cone APM and JEM heat exchangers also mounted to lab end cones CTCS radiator performance estimates <ul style="list-style-type: none"> LTL: 14 kW @ ~ 58 °F MTL: 20 kW @ ~ 36 °F One WP04 PFCS for each radiator 		
	PS/HTC	PHC			
Weight (lb)	2,743	5,486	Weight (lb)	9,812	19,624
Power (W)	538	807	Power (W)	538	1,060
Internal Thermal Control System (ITCS)			Passive Thermal Control System (PTCS)		Orbiter Thermal Control System
<ul style="list-style-type: none"> WP01 baseline—single-phase water U.S. Lab: MTL—25 kilowatts HX LTL—14 kilowatts HX Supports: <ul style="list-style-type: none"> Cupola window frame thermal control— Two refrigerator/freezers racks in MPLM with 1.8 kW/500 lb/hr APM and JEM with 1 MTL and 1 LTL HX each— HX's mounted to lab end cone MTL (61–65 °F): 2.5 kW housekeeping @ 636 lb/hr 22.5 kW P/L @ 2,364 lb/hr LTL (38–42 °F): 4.1 kW housekeeping @ 2,084 lb/hr 8.1 kW P/L @ 416 lb/hr 			Truss-Mounted Equipment	Lab	
	HTC	PHC			
Weight (lb)	1,791	3,582			
Power (W)	600	1,100			

APM Attached Pressurized Module
 BCDU Battery charge/discharge unit
 CTCS Central thermal control system
 DCSU Direct current switching unit
 ft Foot/feet
 HX Heat exchanger
 JEM Japanese Experiment Module
 kW Kilowatt
 LTL Low-temperature loop
 MBSU Main bus switching unit

MLI Multi-layer insulation
 MPLM Mini-Pressurized Logistics Module
 MTL Moderate-temperature loop
 PFCS Pump and flow control subassembly
 PHC Permanent Human Capability
 P/L Payload
 PS/HT Power Station/Human Tended
 TCS Thermal control system
 WP Work Package
 °F Degrees Fahrenheit

Communications and Data Management

The communications and data management system provides distributed data processing, audio/video services, and radio frequency communications. A schematic of this system appears in Figure 23. The primary goal of the redesign is to simplify the system and reduce cost without significantly impacting capability. Other goals include reduction of resources required, improvement of user capabilities, and mitigation of risk areas.

The data system is now based on a single processor design using the baseline multiplexer/demultiplexer, with some enhancements, as a replacement for all standard data processor based units. The redesign architecture also deletes the fiber optic networks and associated hardware components, and uses 1553B buses for all system communications. Other data system hardware changes include replacement of the workstations with portable laptop computers and the use of a modified component of the orbiter multifunction electrical display system to implement an interface with the orbiter.

A simplified software architecture is provided by deleting the Object Management Protocol and many of the data management system standard services used in Space Station *Freedom*. This significantly reduces software complexity and simplifies the software interface with the international partners and with existing ground systems. Deletion of the standard services reduces schedule and program risks for software generation and integration.

Verification is simplified due to testability of the bus architecture, separation of external truss and internal module functions, and distribution of subsystem control. The software development, verification, validation, and build responsibility resides with the system hardware developer. A large centralized software test and verification facility is not required.

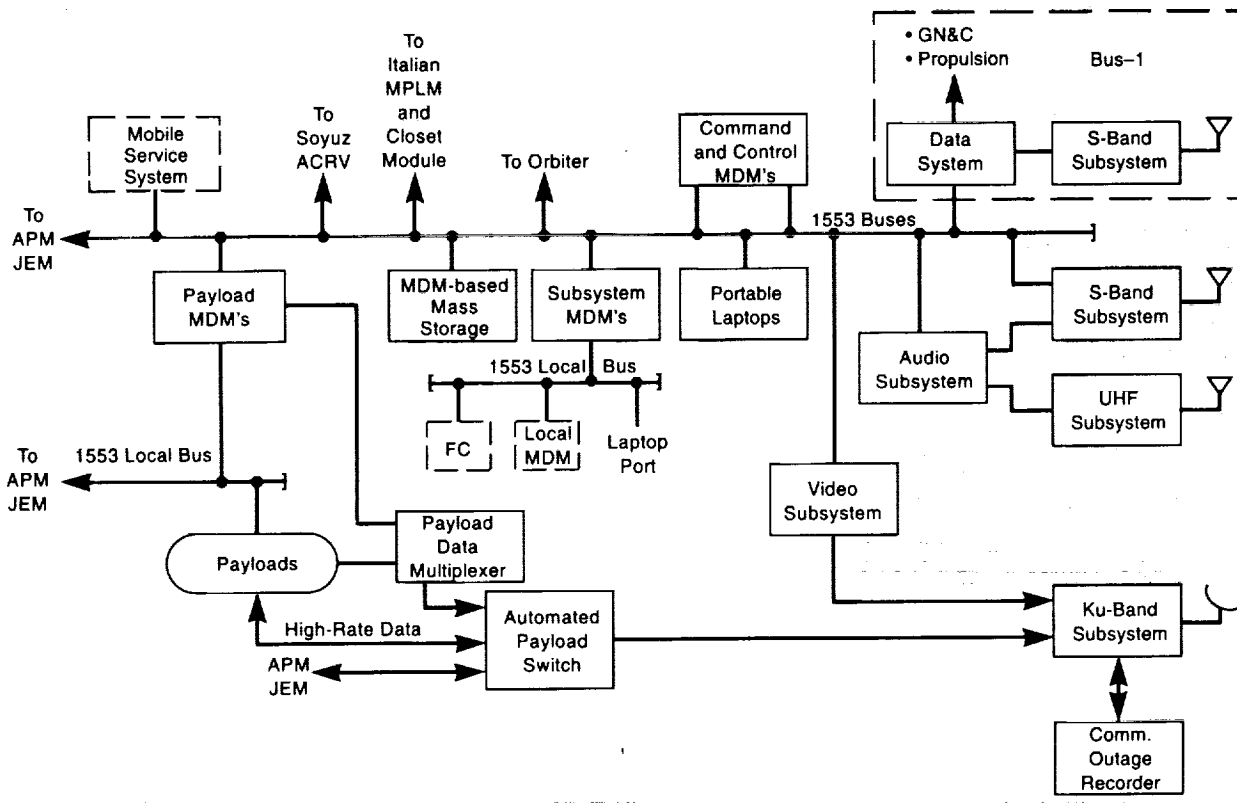

ACRV	Assured crew return vehicle	JEM	Japanese Experiment Module
APM	Attached Pressurized Module	MDM	Multiplexer/demultiplexer
Comm	Communication	MPLM	Mini-Pressurized Logistics Module
FC	Firmware controller	UHF	Ultrahigh frequency
GN&C	Guidance, navigation, and control		

Figure 23.—Communications and data management system.

The 802.4 data bus and fiber optic network interfaces with the international partners are deleted. The 1553B data buses now provide an interface between modules for core and payload data. An enhanced capability for routing and multiplexing payload data is provided by automated payload switches and payload data multiplexers. This provides payload-to-payload data transfers and efficient use of Ku-Band downlink. The Space Station Remote Manipulator System and the Special Purpose Dexterous Manipulator require a dedicated robotics workstation separate from the space station data system.

Several options were considered for both the audio and video systems during the redesign activity. Because of the maturity of the Space Station *Freedom* systems and the need for major modifications to implement any other alternative, Space Station *Freedom* components were selected.

A wireless system is utilized as the primary means of audio communication, allowing a reduction of the hardwired audio terminal units to only one for each major module. The audio terminal units are used primarily for caution and warning annunciation. Both a hardwired interface to the orbiter and the interface to the Ku-Band system that provided audio for video lip synchronization were deleted. The system grows from a zero-failure tolerant to a single-failure tolerant system at Permanent Human Capability. A single audio terminal unit is retained; however, redundancy is provided by the audio terminal units in each of the other modules. Changes to the video system include a reduction in the number of input/output ports, deletion of split-screen processing and the use of commercial camcorders instead of the currently baselined internal video camera. Because the fixed data system workstations are deleted, there is a need to add a video display device. The liquid crystal display unit being developed for the orbiter is used for this function.

The Option A communications and tracking subsystem consists of three separate radio frequency systems: an S-Band system, a Ku-Band system, and an ultrahigh frequency system. Each of these systems utilize the hardware being developed for the baseline Space Station *Freedom* program. The ultrahigh frequency system, which is used to support extravehicular activity, is not implemented until the Permanent Human Capability phase.

The S-Band system is single-failure tolerant and is used to support voice commands and telemetry between the station and the ground via the Tracking and Data Relay Satellite System. The system is capable of receiving uplink data rates of 6 kbps or 72 kbps and of transmitting downlink data at either 12 kbps or 192 kbps. For Option A-1, the existing Bus-1 Space Ground Link System S-Band system will be used until the permanent S-Band system is installed on the station.

Several alternatives for the Ku-Band system were considered. Use of the orbiter reduces cost, but has numerous disadvantages for payloads. None of the other alternatives have any cost advantage over the existing station baseline. The Ku-Band system is capable of transmitting 50 Mbps to the ground via the NASA Tracking and Data Relay Satellite System. It can simultaneously accept up to eight channels of digital payload data and up to four channels of digitized video. The Ku-Band system will be available for the Human Tended phase.

A communications outage recorder has been approved by Space Station Program Level I (PCBD HH900101) for recording payload science data during zone of exclusion and other periods of loss of communications. Several specific implementation approaches are being considered for the communications outage recorder. A decision on a specific design approach will be resolved during implementation.

The redesigned communications and data system is compatible with the ground systems currently being designed for Space Station *Freedom*. These ground systems will support a Consultative Committee for Space Data Systems communications protocol. If necessary, the redesigned communications and data management system design can be modified to be compatible with currently existing ground facilities which accept data in time division multiplexed protocol. Also under consideration is an option to use existing hardware and software that might be available from the orbiter and Spacelab.

In conclusion, the proposed communications and data management system makes use of much of the *Freedom* hardware and software, but reduces the number of different types and the total quantities required. The result is a major reduction in weight, power, and life cycle costs while still providing the functions necessary for station control and monitoring. It also provides a data processing capability that allows users access to scientific data and the capability to transmit the data to the ground.

Environmental Control and Life Support System

The Option A space station environmental control and life support system is divided into six functions defined in Figure 24. The design is based on Space Station *Freedom* hardware, with design scars to allow incorporation of some existing Russian equipment for on-orbit oxygen generation.

The overall environmental control and life support system accommodations for both the crew and payloads at Human Tended Capability and International Human Tended Capability are the same as the current Space Station *Freedom*

Option A Space Station Redesign

design for Man Tended Capability and Permanently Manned Capability, respectively. In the shuttle-tended operations, the basic life support functions for crew habitability will be provided by the shuttle orbiter, including waste management, potable water supply, and extravehicular activity support. When the station is permanently occupied by the crew, these functions will be onboard the Common Module/Hab of the space station. The major changes to the environmental control and life support systems design in Option A from baseline Space Station *Freedom* are summarized as follows:

- Significant environmental control and life support systems hardware was deleted by using Common Core/Lab and Common Module/Hab elements instead of nodes and modules. Deleting hyperbaric operations airlock equipment, including the gas conditioning assembly, simplified the hardware required for extravehicular activity operations. Primary environmental control and life support systems equipment eliminated were the node cabin air conditioning assemblies, tanks, valving, plumbing, and sensors associated with atmosphere supply and control, fire detection and suppression, and air revitalization.
- Simplified approach to meeting failure tolerance for designs at Permanent Human Capability by:
 - Deleting the redundant string of water reclamation and utilizing the 1,200 pounds of stored fuel cell water to satisfy life support during maintenance of the single string and assured crew return vehicle if maintenance cannot be accomplished within 30 days.
 - Deleting one rack of temperature and humidity control cabin air hardware in the Common Module/Hab (utilizing maintenance as a leg of redundancy and orbital replacement units in the redundant temperature and humidity control rack located in the Common Core/Lab Module).
 - Deleting one waste management compartment, using maintenance of the remaining unit as a leg of redundancy, and using "Shuttle-type bags" and/or assured crew return vehicle as the third leg of redundancy for this two-failure tolerant function.
 - Reducing oxygen and nitrogen cryogenic tankage requirements and the number of attachment locations on the truss.

All of the above design changes resulted in launch weight savings, and savings in development costs for hyperbaric airlock operations and in recurring costs for all of the redundant equipment eliminated. Option A eliminated a total of 3,503 pounds of environmental control and life support systems weight from the Space Station *Freedom* baseline for Permanent Human Capability.

In addition, Option A reduced the overall environmental control and life support systems power required at both Human Tended Capability and Permanent Human Capability from the previous requirements at Man Tended Capability and Permanently Manned Capability in the Space Station *Freedom* baseline. A total savings of 208 watts occurred in the shuttle-tended mode, and savings of 1,993 watts occurred in the permanently occupied mode over the Space Station *Freedom* baseline. Significant power savings were associated with the elimination of node equipment peculiar to the Option A configuration. However, other power saving features were implemented that could also be implemented in the current Space Station *Freedom* design or other options being considered in redesign. Specifically, power requirements for each Common Core/Lab Module and Common Module/Hab cabin air fan assembly were reduced by 168 watts, based upon recently completed ventilation tests; the high-temperature catalyst for the atmosphere contaminant control system and the trace gas contaminant monitoring equipment can be operated intermittently and save 435 watts of continuous power; recently completed water reclamation testing also proved the sterilization of waste water prior to processing is not required, and a savings of 268 watts can be realized. Finally, timing of actual power required for water and air regenerative systems (either orbital averages or 24-hour daily averages) showed environmental control and life support systems bookkeeping levels could be lowered.

A re-examination of the trade between cryogenic storage and gaseous storage of the oxygen/nitrogen consumables which must be resupplied for all pressurized element mission phases concluded that the cryogenic storage should be retained, with an option to consider an oxygen-loop regenerative system at Permanent Human Capability. Russian equipment could potentially be used for the oxygen-loop closure equipment (carbon dioxide reduction and oxygen generation). The oxygen-loop closure eliminates oxygen resupply requirements (13,000 pounds per year) at the expense of more environmental control and life support systems power required at Permanent Human Capability (delta increase of 1.6 to 2.3 kilowatts, depending upon NASA- or Russian-provided equipment). The Permanent Human Capability schedule is **not** at risk with this environmental control and life support system approach because the oxygen loop can be left "open" at Permanent Human Capability until the oxygen closure equipment is available.

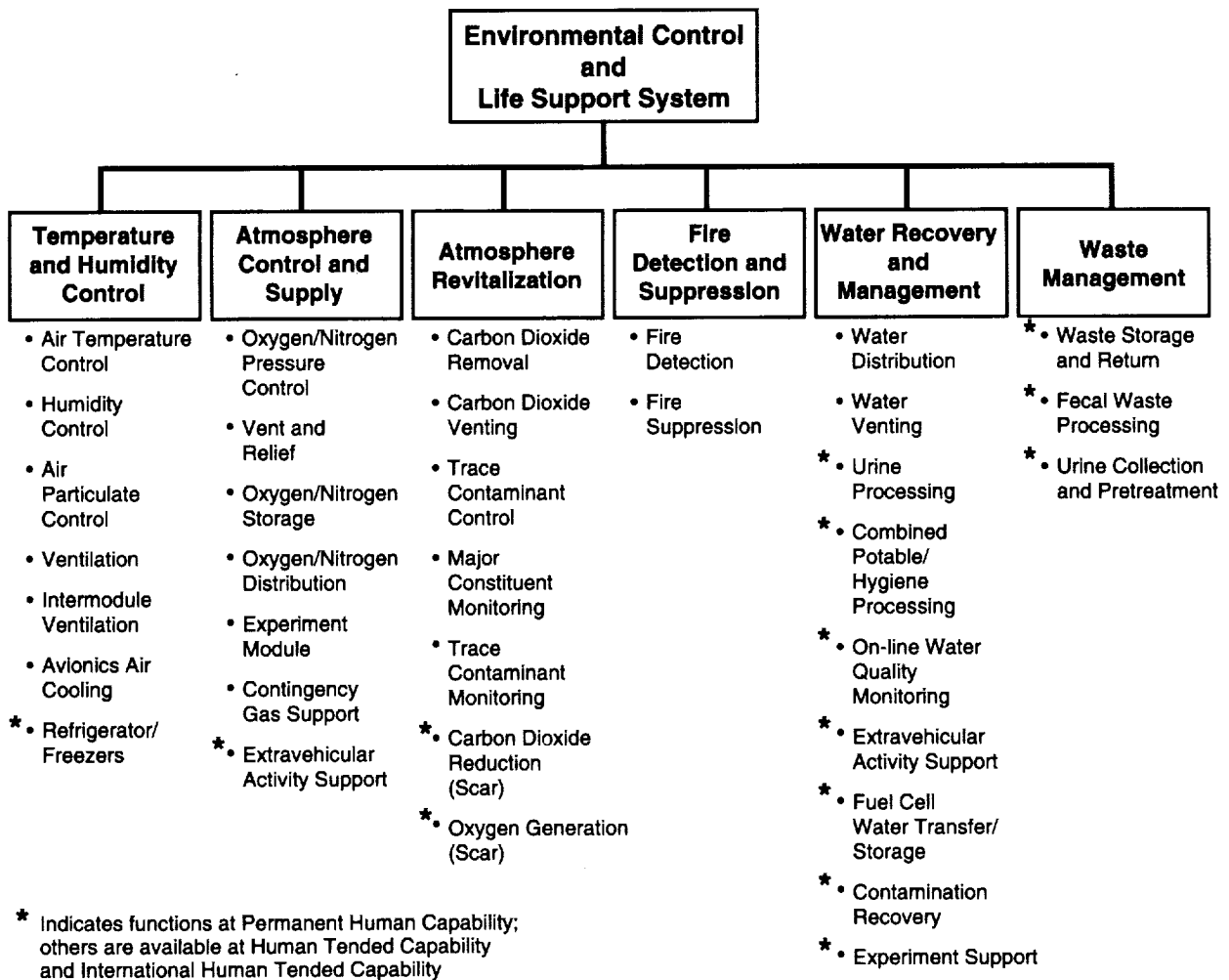

Figure 24.—Option A Environmental Control and Life Support System functions.

Habitability and Crew Systems

The Option A crew systems design is a simplified version of the *Freedom* "man systems." Remaining intact from the *Freedom* baseline are the personal hygiene (shower, waste management compartment, and hand wash/oral hygiene/eyewash), restraints and mobility aids, laundry, galley (oven, refrigerator, trash compactor, nominal and skipped cycle food storage, drink dispenser, and eating utensils), crew health care system, and illumination. Deleted from the *Freedom* baseline are the film stowage chiller (refrigerator), film cameras and film (personal and operational equipment), and safe haven provisions. Deletions affecting crew systems are the wardroom windows and window workstation provisions, and the hyperbaric airlock capability.

Descoped crew system items include reduced clothing volume (lightweight clothing), interfacing partitions, a maintenance work platform replacing the maintenance workstation, and laptop computers replacing the command and

control workstations, element control workstation, and cupola workstation (Figure 25). A dedicated Mobile Servicing System control station for both on-orbit and ground operations will be provided. Additionally, the portable emergency provisions, including breathing masks and portable fire extinguishers, were reduced with the elimination of the nodes, while several crew systems storage racks in the Common Module/Hab Module were reduced in number.

For housekeeping and trash management, a Common Module/Hab trash compactor and vacuum cleaner and bags are provided. Wipes for personal and interior module cleansing are provided in the appropriate compartments, with extras located in the Closet Module. The *Freedom* maintenance workstation has been descoped to a lightweight, portable maintenance work platform capable of restraining orbital replacement units, tools, and small items such as nuts and bolts (Figure 26). It is provided on orbit with the Common

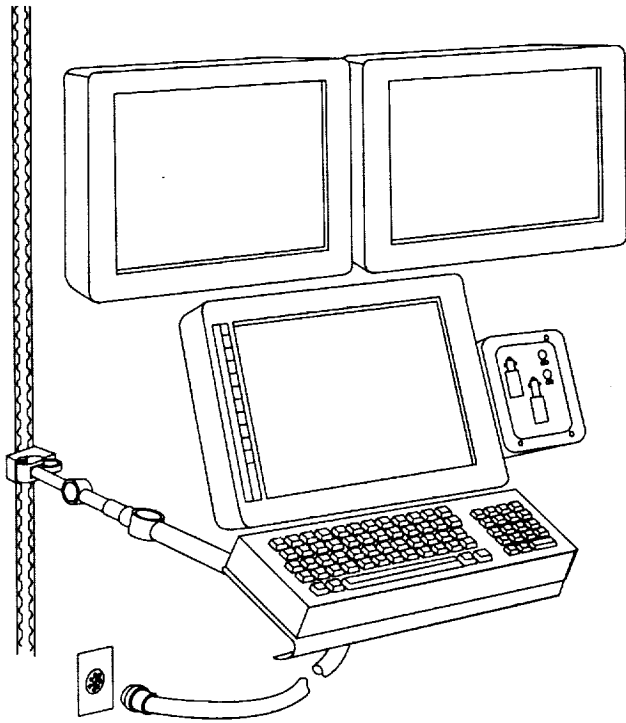

Figure 25.—Laptop workstation.

Core/Laboratory module. Both intravehicular and extravehicular tools are provided at Permanent Human Capability, with the orbiter tools being used prior to that time.

The crew utilizes the orbiter extravehicular activity equipment, including airlock, until Permanent Human Capability, when they are station-provided. The *Freedom* airlock is replaced with a simplified and smaller airlock without hyperbaric capability. The pressure suits used for Option A are the shuttle extravehicular mobility units. The crew and equipment translation aid cart has been replaced with a simplified monorail cart and a manually powered crew translation and work platform. The portable work platform and articulating portable foot restraint are replaced with existing hardware, the Hubble Space Telescope portable foot restraint, and the orbiter manipulator foot restraint, respectively. The *Freedom* temporary equipment restraint assembly and tether shuttle are deleted. Two portable space shuttle foot restraint attachment devices are added for cooperative extravehicular activity and robotics sorties. Crew and vehicle safety are maintained to *Freedom* baseline specifications.

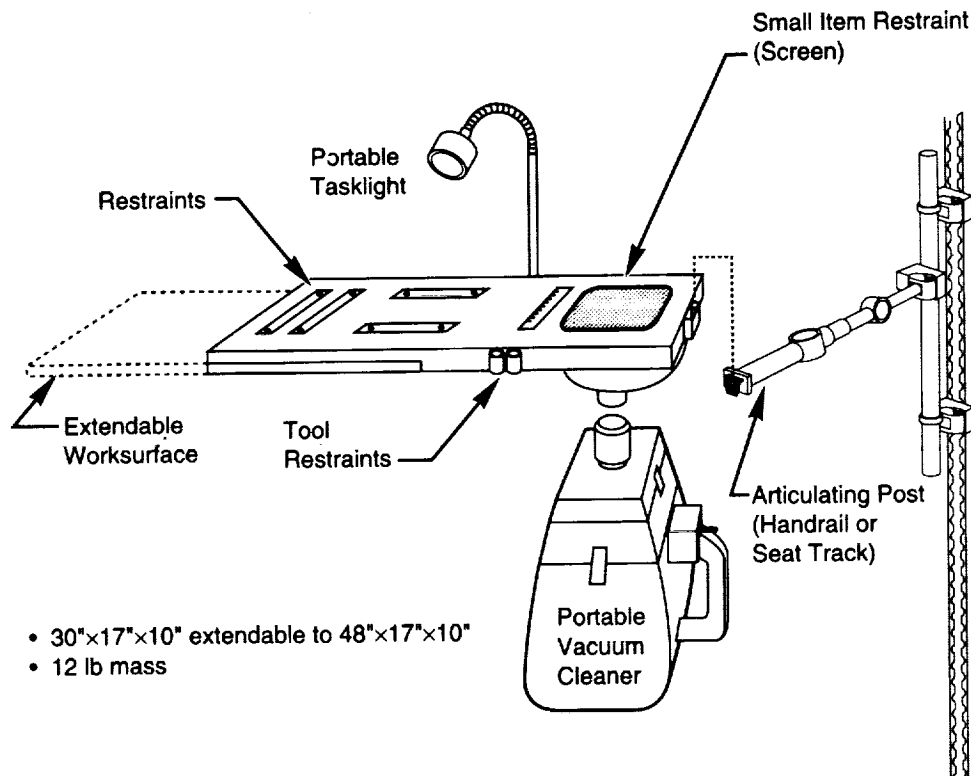

Figure 26.—Maintenance platform.

Structures and Mechanisms

Option A utilizes the existing Space Station *Freedom* structural design, materials ordered, and tooling to the maximum extent possible. The types of mechanisms for Option A are the same as used on Space Station *Freedom*, with a reduced quantity. Several segments of the pre-integrated truss have been eliminated for the A-1 configuration. The components located in *Freedom* truss segments designated as S3, S2, M1 (Figure 27) and P2 and P3 (not shown) are relocated to other remaining truss segments, or their functions are provided by the Bus-1 spacecraft (see also Figure 3). The remaining truss segments require modifications in order to accommodate such functions as utility distribution, orbiter berthing, and avionics. Several other elements from Space Station *Freedom* are also eliminated; these include the solar alpha rotary joint assembly, the Mobile Transporter, and the pressurized logistics module.

A new truss segment between the Bus-1 and the integrated electronics assembly truss segment S4 is required. The structure is approximately 24 feet long to provide the spacing necessary for the Bus-1 reaction control system to clear the solar array panels. An unpressurized berthing adapter interface is provided on the truss segment to accommodate orbiter berthing. The A-1 configuration incorporates the existing design for the segment-to-segment attach system at the Bus-1 interface. The truss-to-integrated electronics assembly interface uses a four point extravehicular activity attachment system similar to a design used on Space Station *Freedom*. Another new structure, similar to the interface between S4 and S3 on *Freedom*, is required to adapt the integrated electronics assembly truss segment to the S1 truss segment. Each end of the S1 truss segment uses the segment-to-segment attach system mechanism. The S1 truss

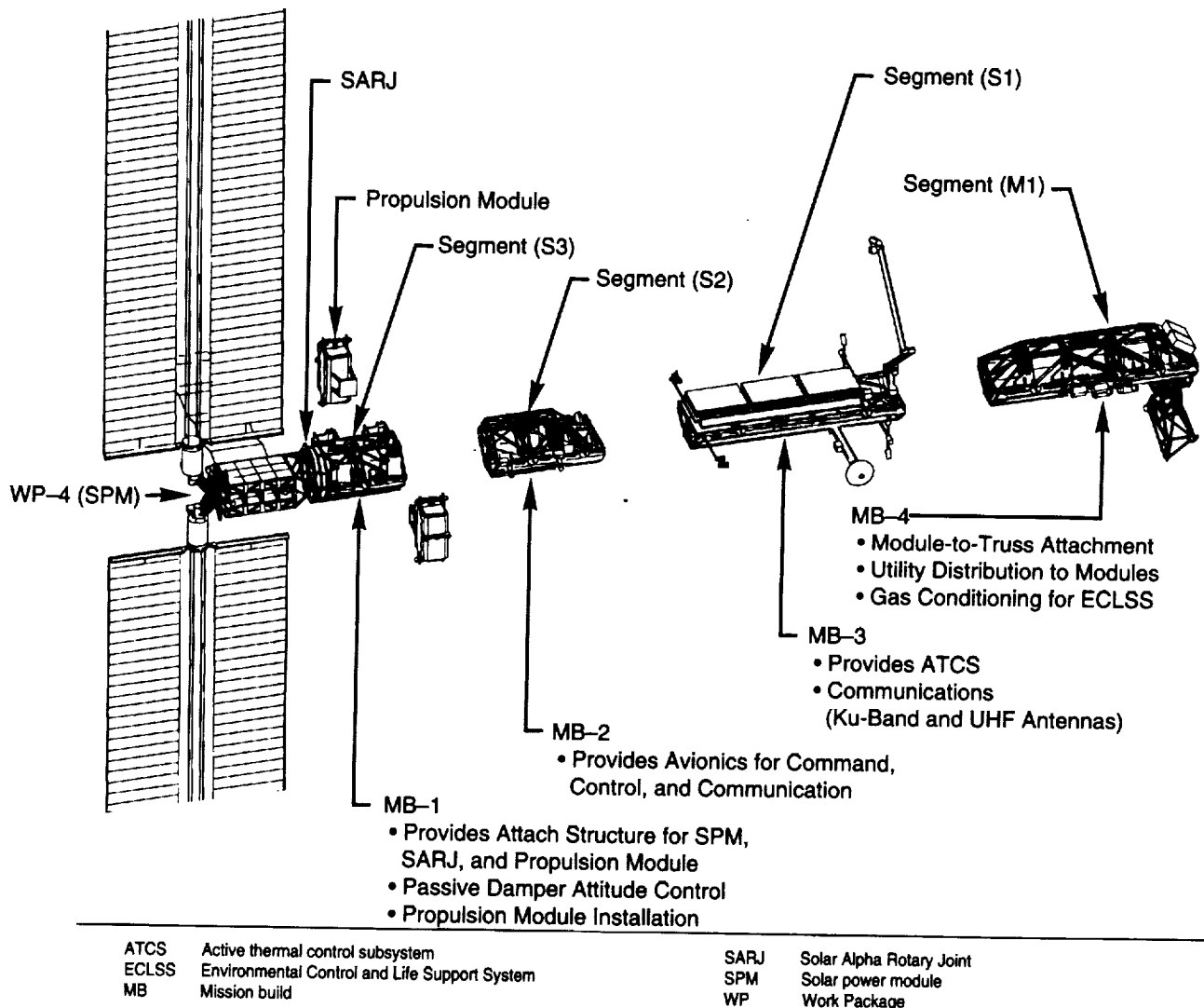

Figure 27.—Space Station *Freedom* integrated truss assembly.

segment will require modification to accommodate subsystems from the deleted truss segments. This includes two radiator panels, repackaging of existing systems, and the addition of an unpressurized berthing adapter interface. Similar modifications and new structures are required for the port truss.

The Space Station *Freedom* Lab module and the node are combined into a single element. Two-thirds of the lab module are merged with the radial port section of the node to form the Common Core/Lab Module (refer to Figure 8). The six node berthing ports (common berthing mechanisms) are retained in the Common Core/Lab, with no changes to the common berthing mechanism. Modifications to the existing node and lab component designs include: addition of six inches to the radial port section of the node, relocation of trunnions, addition of structure to attach the module to the S1 and P1 truss segments, modification of secondary structure to accommodate repackaging, and replacing the node end cone with the lab end cone. The module-to-truss adapter structure is attached to the module through extravehicular activity, and the module will then be connected to the S1 truss segment with the segment-to-segment attach system mechanism. The P1 truss segment will attach to the Common Core/Lab in a similar manner. The module-to-truss adapters are stored on the S1 truss segment prior to assembly. The Common Core/Lab requires additional analyses to assess the implications of the load path changes. The Common Core/Lab structural design is also used for the hab module, with no additional core resources provided at the berthing ports. An 8 inch diameter optical-quality viewport will be provided in one of the hab hatches. This viewport is a derivative of the 8 inch diameter Spacelab optical-quality window.

For the A-2 configuration, truss segments S2, M1, and P2 are deleted and the required functions of those segments are moved to the remaining truss segments. The deletion of the solar alpha rotary joint requires an adapter structure between the integrated electronics assembly and the S3 truss segment. A design similar to that used for Space Station *Freedom* has been selected. The A-2 configuration uses the Common Core/Lab, Common Module/Hab, and the module-to-truss adapter structure.

A detailed Option A loads evaluation is required that includes an indepth flight-by-flight loads assessment for launch and landing, on-orbit dynamics, berthing and docking loads, and reboost loads. All new structures require detailed design and analysis, and the modified truss elements and equipment require revised analyses. For the A-1 configuration, the Bus-1 spacecraft requires loads, dynamic, stress, and fracture mechanics analysis. The Common Core/Lab design requires new and revised drawings; new loads, thermal, stress, and dynamic analyses; and minor tooling changes.

Automation and Robotics

The Shuttle Remote Manipulator System and the Mobile Servicing System are utilized to support assembly, servicing, and maintenance of *Freedom*. In the Option A design, the *Freedom* Mobile Transporter and Mobile Remote Servicer Base System are not included. Although these items perform necessary functions, a trade study led to the conclusion that an alternative method of performing these functions appeared to be technically feasible and less costly. However, it should be noted that the Option A design does not preclude the reincorporation of the Mobile Transporter and Mobile Remote Servicer Base System during implementation.

Translation of the Space Station Remote Manipulator System is accomplished by "stepping" to stationary power and data grapple fixture locations on the truss or modules (Figure 28). Payloads and orbital replacement units, mounted on unpressurized logistics carriers, are transported by the Space Station Remote Manipulator System to payload/orbital replacement unit accommodation locations on the truss (Figure 28). Both power and data grapple fixtures and payload/orbital replacement unit accommodation locations are provided in sufficient quantity and located strategically to allow robotic access to the entire external portion of the station and the orbiter bay when docked. Orbital replacement units with grapple fixture attachments will be transported to the worksite by the Space Station Remote Manipulator System. All other orbital replacement units will be transported by the supplemental crew and orbital replacement unit on-orbit transport and restraint, which translates via a monorail (Figure 28).

The Special Purpose Dexterous Manipulator is part of the Mobile Service System and attaches to the end of the Space Station Remote Manipulator System. It is used to replace robot-compatible orbital replacement units. This usage of the Special Purpose Dexterous Manipulator eliminates the need for extravehicular activity assistance. The Option A design adds ground control capability for the Space Station Remote Manipulator System and Special Purpose Dexterous Manipulator to complement on-orbit control capability. This capability can potentially be used to reduce crew intravehicular activity robotic workload.

Reliability Assessment

The Option A designs assure reliability through a combination of early failure tolerance for critical systems, elimination/reduction of types of orbital replacement units, design simplification, and maximizing use of existing designs/hardware.

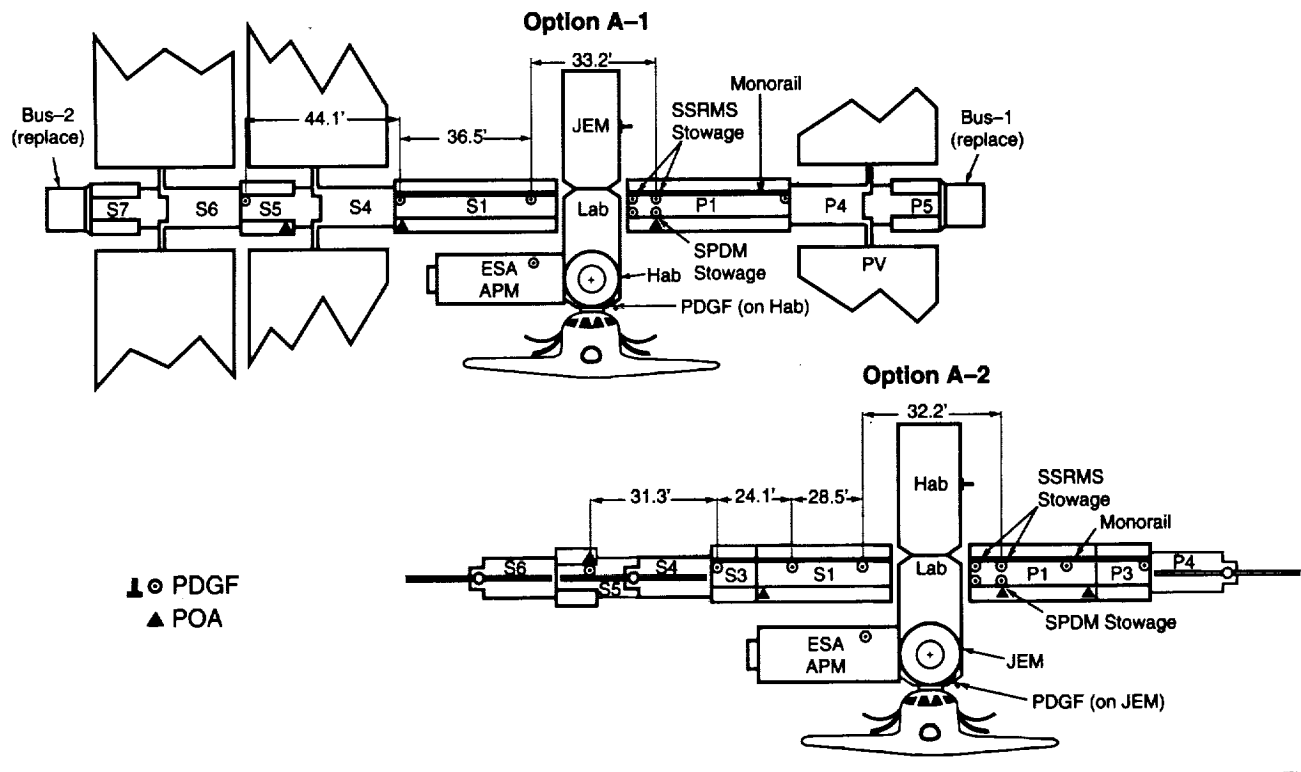

APM Attached Pressurized Module
 ESA European Space Agency
 JEM Japanese Experiment Module
 ORU Orbital replacement unit
 POA Payload/ORU accommodation

PDGF Power and data grapple fixture
 PV Photovoltaic
 SSRMS Space Station Remote Manipulator System
 SPDM Special Purpose Dexterous Manipulator

Figure 28.—PDGF/POA locations for Mobile Service Structure translation and operation.

Option A designs are two-failure tolerant where required to support station survival for the functions of electrical power; data management; thermal control; guidance, navigation, and control; and reboost from the Power Station phase onward. For power and thermal control functions, this represents an improvement over *Freedom* baseline station design and was achieved by redesign of existing power system hardware and use of cross-strapping between the central thermal control and photovoltaic thermal control systems in the event of failures. Option A-1 utilizes the Lockheed developed Bus-1 to accomplish two-failure tolerance for guidance, navigation, and control, and propulsion functions, while Option A-2 retains the *Freedom* baseline designs for those functions.

The Option A designs have reduced complexity and improved commonality by eliminating several types of orbital replacement units in the data management system and thermal control system. Both the central and photovoltaic thermal control systems now use the same single phase ammonia hardware, totally eliminating all hardware associated with the *Freedom* baseline two-phase system. The data management system eliminates all standard data processors,

ring concentrators, and fiber optic network hardware in favor of a design that uses *Freedom* multiplexers/demultiplexers and MIL-STD 1553B data buses. The electrical power system eliminates direct current switching units and battery charge-discharge units. These changes yield simpler designs and eliminate high-maintenance equipment.

The design of nearly all environmental control and life support system hardware is identical to that used on the *Freedom* baseline station. These designs have been thoroughly reviewed and are compliant with current reliability requirements. Use of flight-proven Russian hardware is proposed for carbon dioxide reduction/oxygen generation at the Permanent Human Capability phase.

The Option A designs are less likely to experience critical failures early in the assembly sequence than the *Freedom* baseline design because of increased critical system failure tolerance. System-level mean time between failures will increase for critical systems because of the reduced complexity.

Manufacturing Considerations (Facilities/Ground Support Equipment)

The manufacturing plan for fabrication and assembly of the Option A components and subassemblies utilize essentially the existing tooling, tool designs, and assembly fixtures from the Space Station *Freedom* program and the Bus-1 program. This includes tooling and fixtures that have been purchased or fabricated for these programs. For example, the Common Core/Lab utilizes the same component forming, welding, and subassembly fixtures and tooling used to fabricate the node and lab modules. Additional tooling and fixtures are required to accommodate changes made to the Common Core/Lab to adapt to new interfaces, such as the module-to-truss attachment. The same manufacturing facilities and Ground Support Equipment are also utilized, but require adjustments in the integration, assembly, and checkout, since there are fewer hardware elements. Integration and checkout of the subsystems in the Common Core/Lab differ from the node and lab module procedures, utilizing one contractor rather than separate contractors for the node and lab.

Final fit, function, and performance checks of the integrated launch packages will be performed at the launch site processing facility at the Kennedy Space Center.

Test and Verification Plan and Philosophy

The verification approach employed for Option A differs significantly from the Space Station *Freedom* approach in both scope and scale. A considerable portion of the Space Station *Freedom* verification task addresses verification of distributed systems equipment provided by one Work Package to another as government furnished equipment. The Option A management approach, utilizing a single prime contractor, eliminates the need for this verification activity and allows NASA to focus on verification of the flight elements. In addition to this reduction in scope, the Option A design has a smaller quantity of flight elements, which reduces the scale of the verification task relative to Space Station *Freedom*. A comparable reduction in scope is achieved in the verification process for international partner and participant elements. Option A design features, such as core module interface provisions and data management system simplification (elimination of the NASA-provided data management system orbital replacement units in the Attached Pressurized Module and the Japanese Experiment Module) will significantly reduce the magnitude of the interagency verification activity. That interagency verification activity which remains will be conducted in accordance with the Space Station *Freedom* plan.

The Option A verification plan for a flight element includes three basic steps: (1) flight element verification is performed onsite by the prime contractor, (2) verification of integrated flight elements is performed at Kennedy Space Center, and (3) on-orbit checkout. NASA takes delivery of the flight element subsequent to successful completion of step 2. Step 1 encompasses verification of the flight element against element-level requirements (i.e., configuration end item specification). Step 2 addresses verification of the interfaces and mutual functionality of interfacing flight elements. Step 3 verifies the operational readiness of the fielded flight element.

Just as the modular architecture of Option A requires the station to be assembled in stages, it also allows the station to be verified in stages. A hand-off strategy underlies the integrated verification testing. In this strategy, a flight element arrives at Kennedy Space Center, and subsequently undergoes integrated testing with flight elements to which it interfaces but which launch on preceding assembly flights. Prior to its launch, this same flight element will undergo integrated testing with interfacing flight elements which launch on succeeding assembly flights. Prior to their launch, these flight elements will in turn undergo integrated flight testing with interfacing flight elements which launch on succeeding assembly flights, and so on. This test flow is shown in Figure 29 for the flight elements comprising the first five assembly flights. Note from Figure 29 the integrated test of the flight elements comprising the first three assembly flights, which will verify the mutual functionality of the flight elements comprising the Power Station phase. Note also that the Common Core/Lab arrives prior to the launch of assembly flight three, allowing the physical flight hardware interfaces to be verified for these flight elements. Where a flight element launches prior to the arrival at Kennedy Space Center of an interfacing flight element (e.g., the launch of the Common Core/Laboratory prior to delivery to Kennedy Space Center of the Japanese Experiment Module), simulators will be employed in the integrated testing. However, the hand-off strategy also supports verification of simulators. Note from Figure 29 that the Mini-Pressurized Logistics Module to Common Core/Lab interface is verified in an integrated test. The physical interface (i.e., berthing mechanism) and a significant portion of the functional interface of the Common Core/Lab simulator can subsequently be verified against the Mini-Pressurized Logistics Module, prior to usage of the simulator in integrated testing with the Japanese Experiment Module, Attached Pressurized Module, Common Module/Hab, and other pressurized elements including the Soyuz assured crew return vehicles.

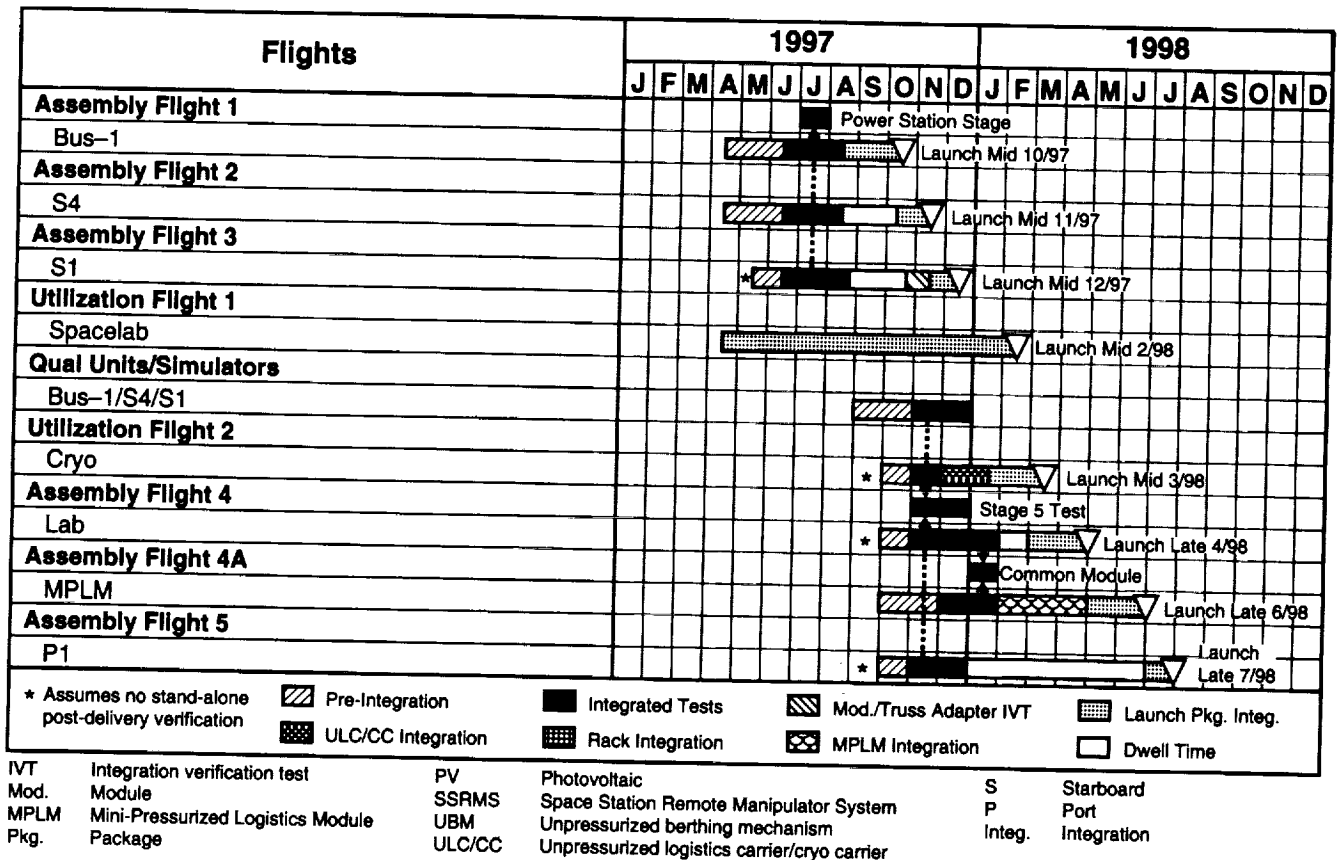

Figure 29.—Testing and launch processing flow.

Integration Factors

Interface reduction has been accomplished in Option A by reducing the number of truss segments required for the configuration from that required by *Freedom*, and by integrating the functions of the *Freedom* modules and nodes into the Option A common modules. Utilization of the Bus-1 guidance, navigation, and control, and propulsion will require some modifications of the existing Bus-1 systems to provide compatibility with the space station. While significantly fewer in quantity, the technical complexity of element-level interfaces for Option A is comparable to that for *Freedom* for the NASA elements. However, in general, the interfaces for the international partners have been simplified. The electrical and thermal interfaces between the Common Core/Lab and the European Attached Pressurized Module have been reconfigured to allow internal connectivity versus the *Freedom* method of requiring extravehicular activities for connection. The thermal interface between the Common Core/Lab and the Japanese Experiment Module has likewise been reconfigured to allow internal connectivity. The necessity for providing data management system orbital replacement units between partners has been eliminated.

The Option A command and telemetry system is designed to be compatible with the *Freedom* ground system design. If the Bus-1 spacecraft is employed, its command and telemetry system must be used until assembly flight 2; the Bus-1 communications system is not compatible with the Tracking and Data Relay Satellite System and will require interaction with Department of Defense ground facilities.

Option A element development and delivery schedules have been developed to ensure sufficient time is available to support the station launch and assembly. Modifications to the orbiter fleet and the Bus-1 spacecraft can be accomplished in the time available to support the space station schedule.

Orbiter modifications include incorporation of extended duration orbiter modifications for use during the Human Tended Phase. Modifications to Bus-1 consist of relocating the electrical power solar array and main thrusters, adding power and data grapple fixtures, making revisions to the control moment gyro management software, and adding a 1553B data bus interface.

Performance—Assessment of Capability

Key Requirements and Accommodation

General Requirements

The requirements imposed on the redesign activity consist of those imposed by the Program Requirements Document and the Program Definition and Requirements Document on the baseline Space Station *Freedom*, top-level requirements imposed by the NASA Administrator, requirements derived from existing international agreements, and additional requirements generated by the Station Redesign Team (see the summary list of the latter three types of requirements in Appendix B). Although the requirements are very demanding, Option A meets all safety requirements and meets most others within the constraints of the predominant driver—cost—and more closely satisfies some requirements than does *Freedom*.

Areas where Option A does not meet the Program Requirements Document and/or Program Definition and Requirements Document requirements are:

- The Space Station Remote Manipulator System meets the schedule requirement for launch prior to Human Tended Capability in Option A-2, but is not launched until the next flight after Human Tended Capability in Option A-1.
- Nine International Standard Payload Rack locations are provided in the Common Core/Lab Module at Human Tended Capability.
- Whereas the probability of no penetration for Option A exceeds that of *Freedom*, it still does not completely meet the required probability of no penetration of 0.9955 per critical element.
- The fiber distributed data interface has been replaced with the 1553B data bus. The 802.4 interface will be available within the international partner modules only.
- The Mobile Transporter has been deleted, but the function is provided by alternate means.
- Other areas, such as microgravity vibratory acceleration requirements, show improvement over *Freedom* capabilities, but more thorough analysis is necessary to ascertain exact levels met by Option A.

The Station Redesign Team requirements included some capabilities that were not in *Freedom*, and cannot be met by Option A without significant cost impacts. The new requirements for video compression of at least six channels and

uplink video of one channel with medium fidelity are not met by Option A. Other areas where Station Redesign Team requirements are not met are:

- Optical viewing requirements are met using an 8-inch window instead of the 20-inch window.
- Option A meets the normoxic condition requirements as stated in the Engineering Design Guidelines of the Station Redesign Team requirements, but the more stringent carbon dioxide requirements in the Science, Technology, and Engineering Research Design Guidelines will require additional payload power.
- No early or late access to the space station is provided at the launch or landing sites, except as provided via orbiter middeck utilization.
- Fire protection is not two-failure tolerant. The requirements matrix lists fire protection as a two-failure tolerant function. This is an expansion in requirements from the current *Freedom* program, as well as other programs with humans in space.
- Manual override without the data management system is not provided. The Option A design is consistent with the *Freedom* design.

Safety Requirements

General

The approach utilized in Option A is to provide a design that is two-failure tolerant against loss of crew or station. This is primarily accomplished by providing the appropriate failure tolerance for crew and station survival functions (e.g., life support, attitude control, reboost, and supporting utilities). For crew survival functions, Option A implements the same approach utilized on the baseline *Freedom* station, with the orbiter or assured crew return vehicle providing a third leg of redundancy for non-time-critical failures.

Crew Survival

Atmosphere control failure tolerance is accomplished early by incorporating two pressure control assemblies in the Option A lab module. This, combined with the orbiter, provides two-failure tolerant atmosphere control starting at Human Tended Capability. A third pressure control

assembly arrives on orbit with the launch of the Option A hab module to ensure pressure control capability even if the lab must be isolated due to an undesired event (e.g., contamination or depressurization). Prior to Permanent Human Capability, air revitalization is provided by the lab air revitalization system, atmosphere dilution, and the orbiter. At Permanent Human Capability, an additional air revitalization system rack is provided in the hab module, thereby eliminating the need to dump atmosphere following failure of the lab air revitalization system or following a lab isolation event. Option A utilizes the *Freedom* fire protection baseline to provide automatic fire detection and suppression in the lab and hab. Option A is a modular concept that provides the crew with the capability to isolate an undesired event (i.e., depressurization, contamination, or fire) from the other habitable volumes by closing hatches and intermodule ventilation valves.

Assured Crew Return Capability

Capability to return crew members during an emergency is provided by two Soyuz capsules, each of which can carry two crew members and medical gear. Both Soyuz capsules are attached to the hab module.

End of Life Safe Disposal

Option A, like the *Freedom* baseline, is based on a modular concept that facilitates end of life safe disposal by utilizing the space shuttle to return modular segments to Earth. This eliminates the re-entry concerns experienced by the Skylab program.

General Science Accommodation Capability

A major goal of the Space Station *Freedom* redesign activity is to ensure that any new design, or modification of the existing design, adequately accommodates a wide array of microgravity (micro-g) science, life sciences, and external attached payloads. Particular importance was assigned to the accommodation of microgravity sciences and life sciences payloads that require a long-term stable microgravity environment. The Option A designs provide such an environment and the resources required to accommodate a wide array of scientific, commercial, and technology payloads.

The full accomplishment of life sciences payloads on Space Station *Freedom* requires the accommodation of a centrifuge facility for variable microgravity-level research. Adequate power, volume, and mass resources are provided by Option A in the three laboratory modules for accommodation of a centrifuge facility or facilities. A 1.8 meter centrifuge can be accommodated in racks inside the

laboratory module, and provisions are made at to accommodate a 2.5 meter centrifuge module and life sciences support equipment at Permanent Human Capability. Thus, the Option A concept shows considerable capability to accommodate the life sciences program.

A high-quality microgravity environment is essential to successful microgravity and life sciences research programs on the space station. Such an environment is provided by the Option A design. During nominal operations (when the orbiter is not docked), the microgravity profiles are quite good throughout the assembly sequence. During Human Tended Capability, with only the Common Core/Lab in operation, the entire module exhibits an environment on the order of one micro-g or less. During International Human Tended Capability, when the Japanese Experiment Module, European Attached Pressurized Module, and Common Core/Laboratory are all operational, all laboratories are within the two micro-g zone, with the majority of laboratory space lying within the one micro-g zone, as shown in Figures 30 and 31.

During off-nominal operation (when the orbiter is docked), the space station is skewed in orientation and the micro-g environment degrades. When the orbiter is docked at Human Tended Capability, the Common Core/Lab is within a four micro-g zone, and at International Human Tended Capability the majority of all three labs are within the four micro-g zone, with portions of the Japanese Experiment Module extending outside that zone. Also, it is possible to adjust or modify the Option A configuration to improve the micro-g environment.

Attachment locations for external payloads are provided on various sides of the truss (Figures 32 and 33), and other potential payload mounting locations are also shown here. Viewing in the ram and wake directions, as well as in the nadir and zenith directions, is achieved by proper orientation of the payloads mounted at these locations. Additional external mounting locations are provided on the Japanese Exposed Facility (10 sites). An 8 inch diameter scientific window is provided in a hatch located on a radial port in the hab module in Option A-1 and in the end of the closet module in Option A-2 at Permanent Human Capability. An earlier, similar window is provided in a radial port hatch in the lab for both Options A-1 and A-2, but this window is later covered by the cupola upon its delivery to the station. Earth sciences payloads can use the windows and external mounting locations. Astronomy and astrophysics payloads can also use external mounting locations. Space environment measurement, materials exposure, and engineering technology payloads can be accommodated at a range of ram, nadir, zenith, and wake locations provided by the Option A concept.

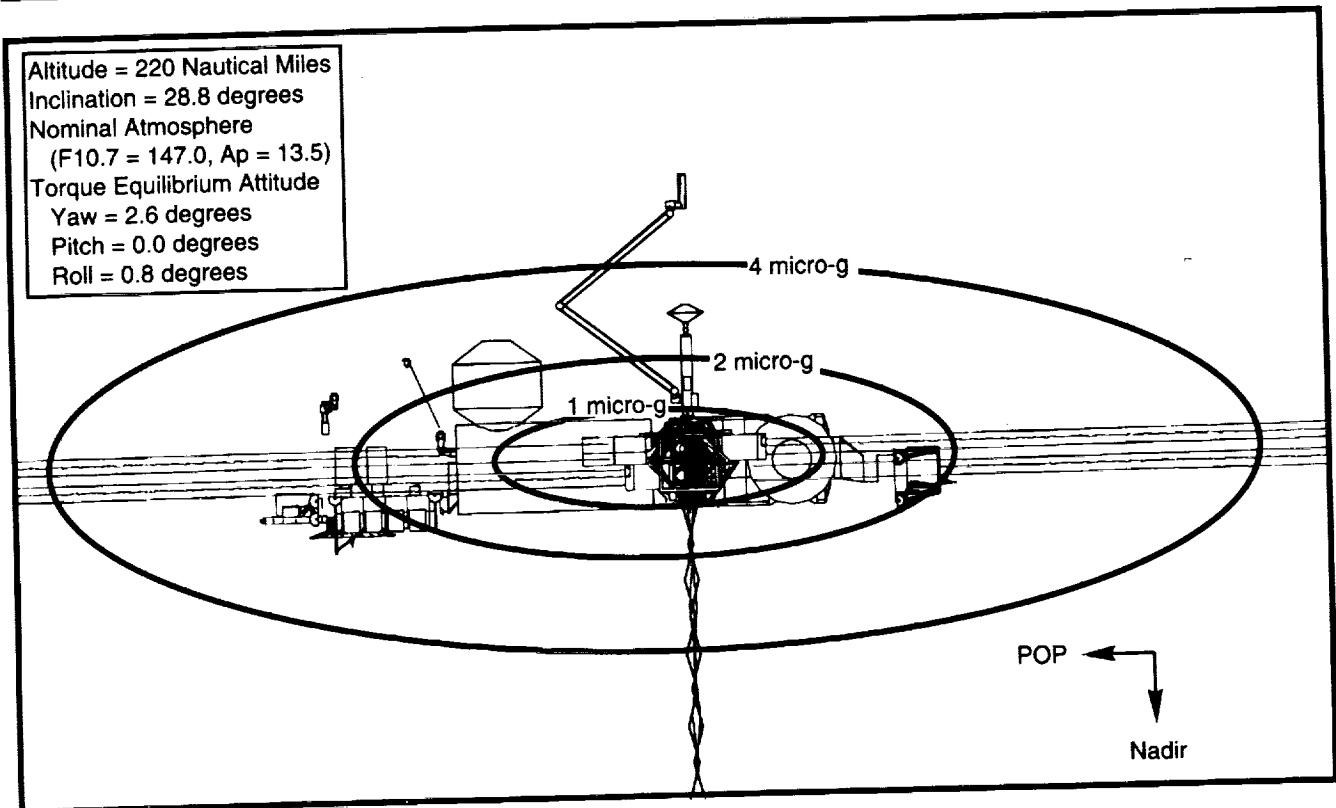

Micro-g Microgravity
POP Perpendicular-to-orbit plane

Figure 30.—Option A-1 microgravity zones at International Human Tended Capability (view 1), arrow mode, without orbiter.

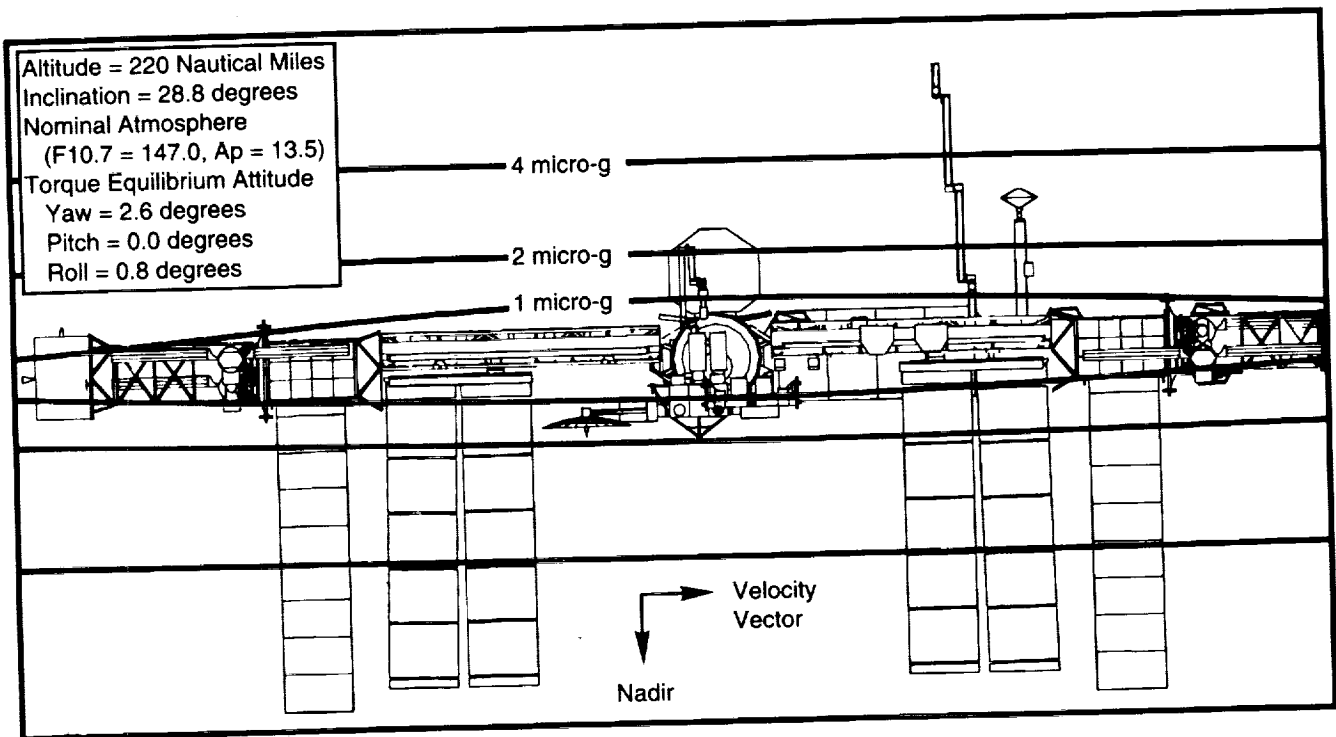
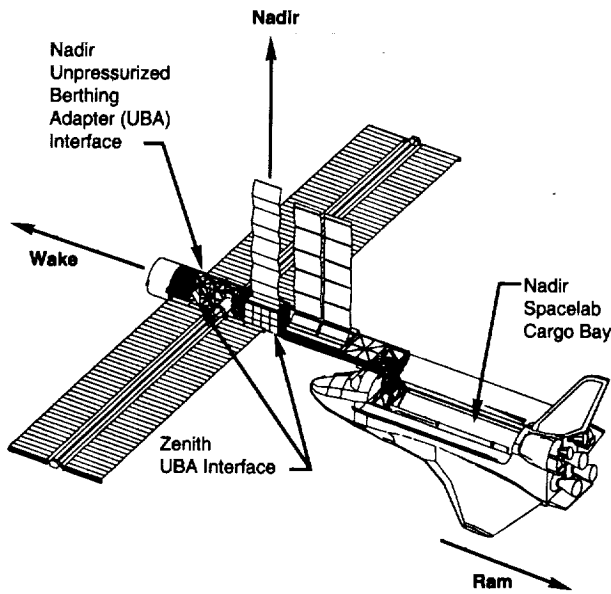
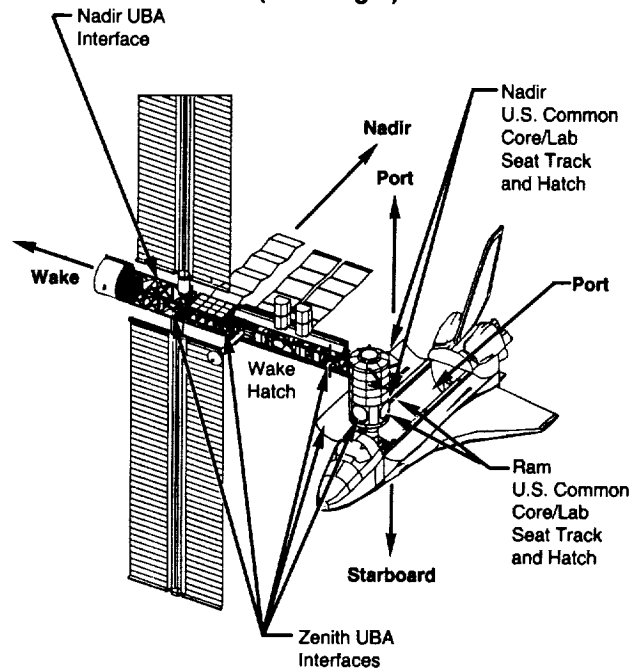

Figure 31.—Option A-1 microgravity zones at International Human Tended Capability (view 2), arrow mode, without orbiter.

**A-1 Power Station
(Assembly Flight 3)**



**A-1 Human Tended Capability
(User Flight)**



**A-1 International Human Tended Capability
(Assembly Flight 12)**

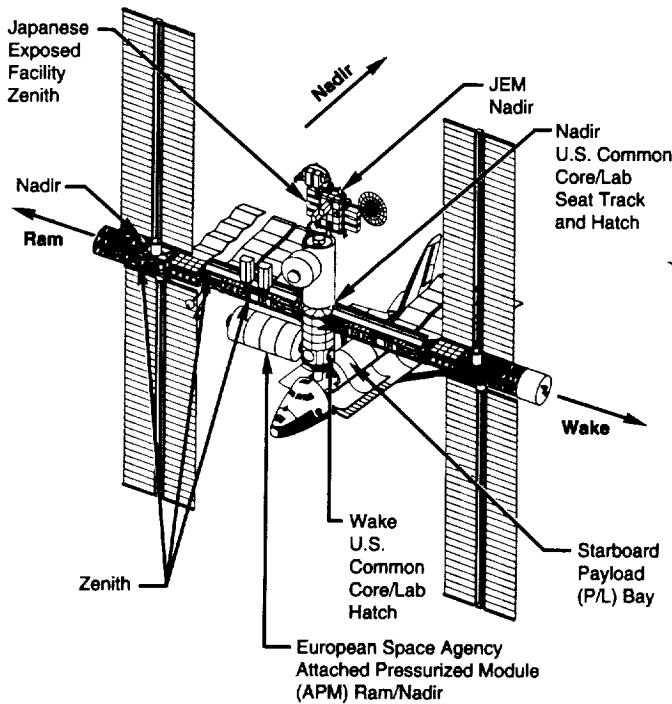

**A-1 Permanent Human Capability
(Assembly Flight 16)**

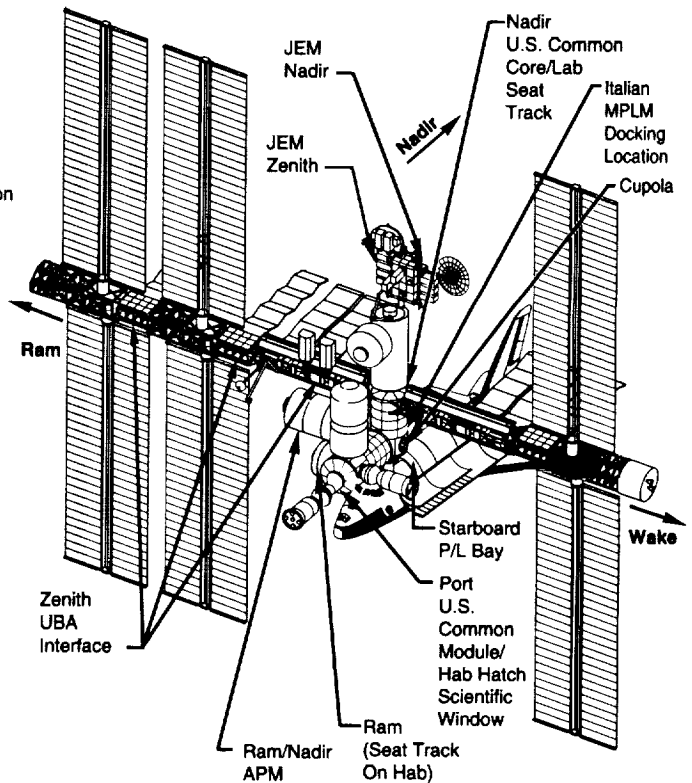
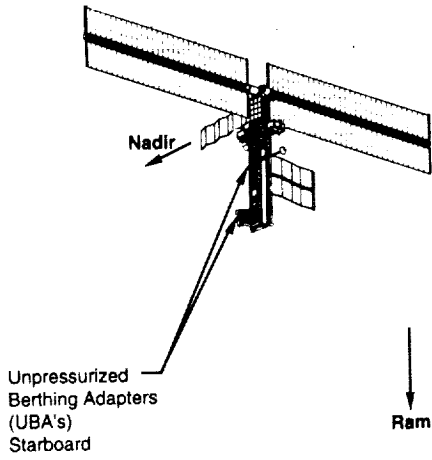
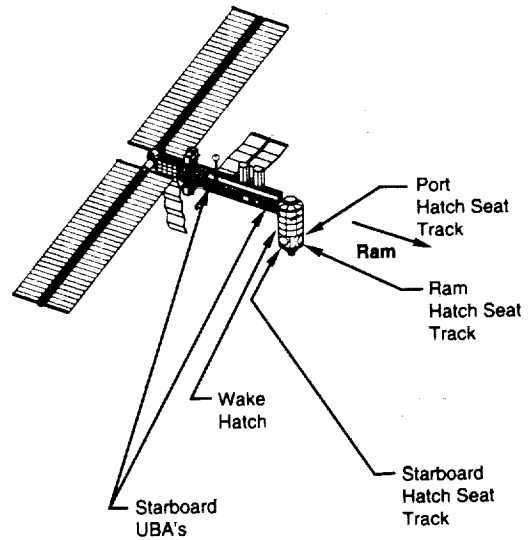

Figure 32.—Option A-1 candidate attached payload locations.

A-2 Power Station



A-2 Human Tended Capability



A-2 International Human Tended Capability

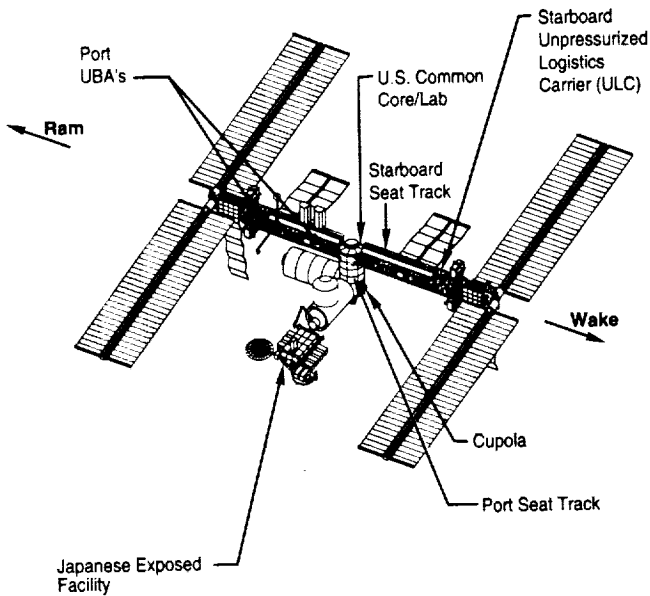

A-2 Permanent Human Capability

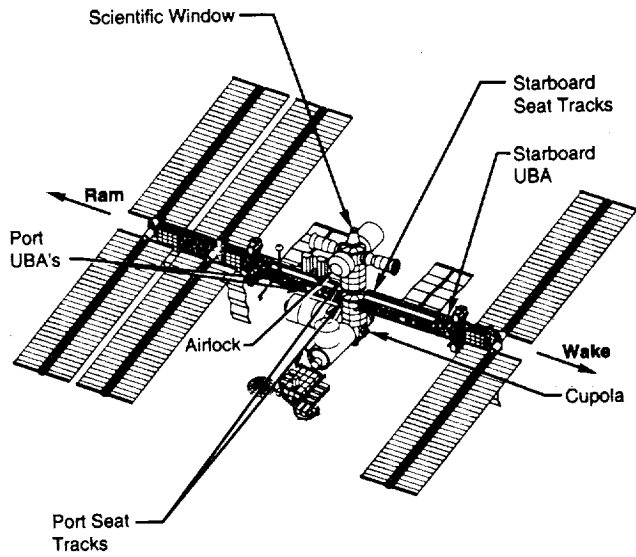

Figure 33.—Option A-2 candidate attached payload locations.

Payloads can be operated during times when the station is occupied and unoccupied, at all buildup stages. Several utilization (i.e., payload operations) missions are flown between station assembly and logistics flights. The four standard phases of Option A buildup offer “plateaus” at which station operation and utilization can continue for specific lengths of time before proceeding to the next phase. If such an operation were planned to continue for any length of time at a given plateau, the station could be “optimized” for operation at that plateau. However, since greater amounts of science and greater efficiencies are possible at higher plateaus, there is an incentive to continue building towards higher plateaus rather than stopping.

Payloads may need to time-share power resources at some stages in the buildup. However, a great amount of science can be done in this mode of operation since the station is on orbit continuously. Multiple payload mounting locations, both internal and external, are a valuable resource attained at a fairly small expense. Internal mounting locations can be multiplied and additional, smaller payloads accommodated by use of an “express rack” that accommodates drawer-size payloads.

One other salient feature of the Option A concept that will affect payload operations is an occasional reorientation to another arrow mode at high beta angles to offset power degradation, but 8 to 56 consecutive days are spent in the primary orientation. If longer periods at one orientation are needed, the station can forego the high beta angle reorientation, achieving continuous time in the primary orientation at the expense of nominal power degradation.

Resources Available to Users

Payloads for the station will be derived from an inventory of equipment that currently exists (e.g., most will be transitioned from existing programs such as Spacelab) or new payloads that have been defined specifically for the space station era. Also, it has been assumed that in order to be technically justifiable, any redesigned space station must show an increase in resources over the existing payload accommodation capabilities of the space shuttle and Spacelab. These issues have been analyzed and assessed for Options A-1 and A-2. As a result of this analysis, it was determined that these options compare favorably to the *Freedom* baseline design and, at the same time, meet or exceed the capabilities of the space shuttle with Spacelab in all phases of the buildup sequence.

In order to assess the payload accommodation characteristics of the two options, nine key parameters, or “resources,” were chosen as a basis for comparison to the baseline

Freedom design. The specific payload accommodation characteristics, or “resources,” are identified in Table 11. Also identified in Table 11 are values (e.g., number of racks, average payload power in kilowatts, etc.) for each parameter for two of the baseline *Freedom* phases and the four buildup phases planned for the redesigned station. However, some elaboration is required on the Power Station phase which utilizes the orbiter and Spacelab for science payload accommodation. During the Power Station phase of Option A assembly, the space shuttle with Spacelab provides an on-orbit research capability to accommodate up to eight equivalent double racks of microgravity materials processing, life sciences, and other science experiments for extended operations of up to 20 days. These orbiter and Spacelab flights utilize the early Space Station elements primarily as a source of power and attitude control. The orbiter and Spacelab together provide all other necessary functions required to operate payloads during this phase. Resources provided at the other phases are shown in Table 11.

In addition to the resources listed in Table 11, other systems are available to support users. A communications outage recorder has been added to the data system, as well as an optical window for Earth observations. Other key items of user support provided by *Freedom*, such as the acceleration mapping system, the refrigerator/freezer space, pressurized nitrogen gas, potable water, and a vacuum source, have been maintained.

Experience on Spacelab missions has shown that payload research and development operating time depends upon several key factors. One is payload consumables. Another factor is crew time available for payload operations. Reductions in both external and internal maintenance and simplification of station systems enable additional time to be made available for payload operations. Moreover, this same reduction in replacement/maintenance items—together with an increase in logistics capability—enables the Option A space station to supply more payload consumables, thereby achieving more efficient and prolonged payload research and development operations. Payload volume and power are also major factors in accommodating research and development payloads on space vehicles. Option A provides nine user racks at the Human Tended Capability phase and a total of 39 user racks with the addition of the two international partners' laboratories. Although this is fewer racks than provided in *Freedom*, there is still a significant volume available to users. Total user power (i.e., yearly average payload power) and power per rack are both greater than that available in *Freedom*. This, combined with the increase in available crew time and payload consumables will result in greater research throughput per rack.

Table 11.—Resources available to users.

Resource	SSF Baseline		Power Station		HTC		International HTC		PHC	
	MTC	PMC	A-1	A-2	A-1	A-2	A-1	A-2	A-1	A-2
Payload Racks (ISPR's)	13	44	8	8	9	9	39	39	39	39
Yearly Average Payload Power (kW) (With/Without Orbiter)	**** 12/21.5	**** 30/30	10.1/21.7	10.3/21.9	8.2/17.7	7.9/17.5	19.8/29.3	18.3/27.9	38.1/38.1	36.6/36.6
Payload Available Crew Persons	3	3	4	4	2	2	2	2	4	4
Payload Thermal—Air & Liquid	yes	yes	yes	yes	yes	yes	yes	yes	yes	yes
Number of Payload Racks at Microgravity Environment (Equal to or less than one µg/two µg)	0/10	28/44	7/8	7/8	9/9	9/9	29/39	18/27	8/36	5/30
Payload High-Data Rate (Mbps)	43*	43*	43**	43**	43*	43*	43*	43*	43*	43*
Payload Video Downlink (number available)	1*	1*	1**	1**	1*	1*	1*	1*	1*	1*
Payload Multiple Venting (Waste Gas)	yes	yes	yes	yes	yes	yes	yes	yes	yes	yes
Attached Payload Sites (Actuals/Candidates)***	4/4	14/14	3/4	2/3	4/10	2/9	15/19	14/18	15/22	15/22

* Shared resource
 ** To be provided only if program stops at Power Station.
 *** Actuals exclude the orbiter payload bay.
 **** Space Station *Freedom* payload allocation. (The yearly average is unavailable and may be higher than the allocated power.)

HTC Human Tended Capability
 ISPR International Standard Payload Rack
 kW Kilowatts
 µg Microgravity

Mbps Megabits per second
 MTC Man Tended Capability
 PHC Permanent Human Capability
 SSF Space Station *Freedom*

Payload power comparisons are depicted graphically in Figures 34 and 35 for Options A-1 and A-2. Up to 12 kilowatts of power is provided at some user rack locations. In summary, cost reductions achieved by Option A, on balance, have not unfavorably impacted payload accommodations. The increases in power, payload logistics/consumables, crew time, and general support equipment have increased the utility of the station.

Accommodation of International Partners

International partners and participants with NASA in the *Freedom* program include the Italian Space Agency, the National Aerospace Development Agency of Japan, the European Space Agency, and the Canadian Space Agency. Each international partner has agreed to provide specific elements and services for *Freedom* in exchange for portions of the internal and external user allocations. The percentage

utilization for Option A is the same as for *Freedom*, which can be summarized as follows:

- NASA receives 97 percent utilization of the U.S.-provided laboratories
- NASA receives 46 percent utilization of the Japanese Experiment Module and the European Attached Pressurized Module
- NASA receives 4 of the 10 Japanese Experiment Module Exposed Facility ports
- The Canadian Space Agency receives 3 percent utilization of the U.S. laboratories, Japanese Experiment Module, and the European Attached Pressurized Module
- The Japanese Space Agency receives 51 percent utilization of the Japanese Experiment Module and 3 Exposed Facility ports
- The European Space Agency receives 51 percent utilization of the Attached Pressurized Module.

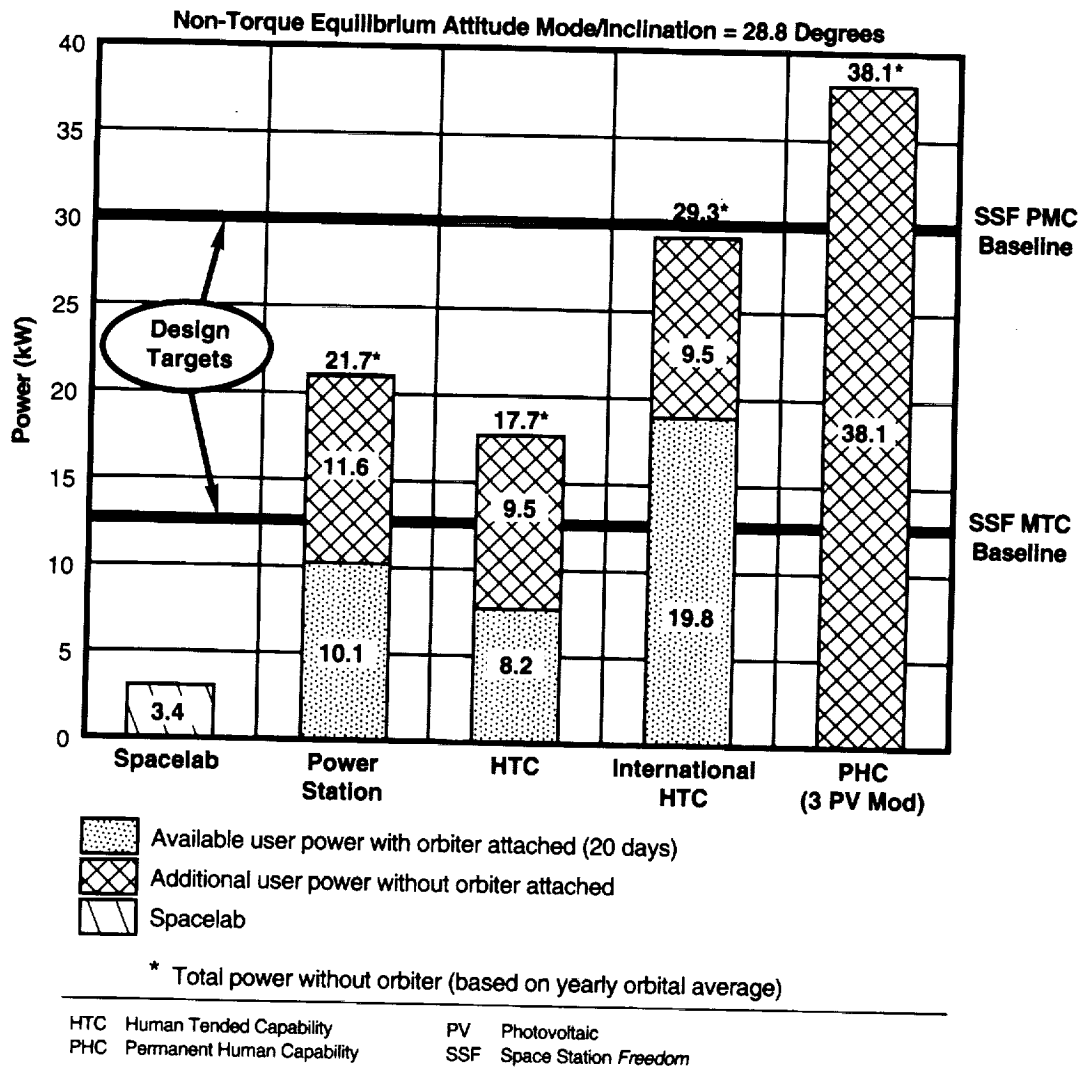

Figure 34.—Option A-1 available payload power comparison.

The utilization includes payload volume, electrical power, and data services. Also, a current agreement exists with the Italian Space Agency to provide two Mini-Pressurized Logistics Modules and an optional mini-lab. In return, the Italian Space Agency will receive 0.5 percent of NASA's user allocation for providing the Mini-Pressurized Logistics Modules and an additional 0.5 percent if the mini-lab option is exercised.

Option A potential impacts can be summarized in the following four categories: (1) utilization/payload resources, (2) attachment/interface, (3) location/orientation, and (4) schedule. The impacts on each international partner for each of these categories are summarized in Table 12.

Resources available to payloads in the Option A design are essentially the same as those available to payloads on *Freedom*. Because utilization of the space station is allocated on a percentage basis, the only international partners impacted from the slight payload volume reductions will be

the Canadian Space Agency and the Italian Space Agency. This is because these agencies are allocated 3 percent and 0.5 percent, respectively, of NASA's allocation, which is slightly reduced in the Option A design compared to *Freedom*. The size/volume of the Japanese Experiment Module and the European Attached Pressurized Module are not impacted by the Option A design. NASA and all international partners will equally share in a slight reduction of some data services posed by the Option A designs relative to *Freedom*. Quantification of these reductions can be found in the section on Resources Available to Users.

One primary impact has been identified under the "attachment/interface" category. Specifically, the interface for the Canadian Space Agency's Mobile Servicing System has changed as a result of the deletion of the NASA-provided Mobile Transporter. This impacts the manner in which the Canadian-provided Space Station Remote Manipulator System and Special Purpose Dexterous Manipulator interface to the truss. These changes, as well as changes in the specific

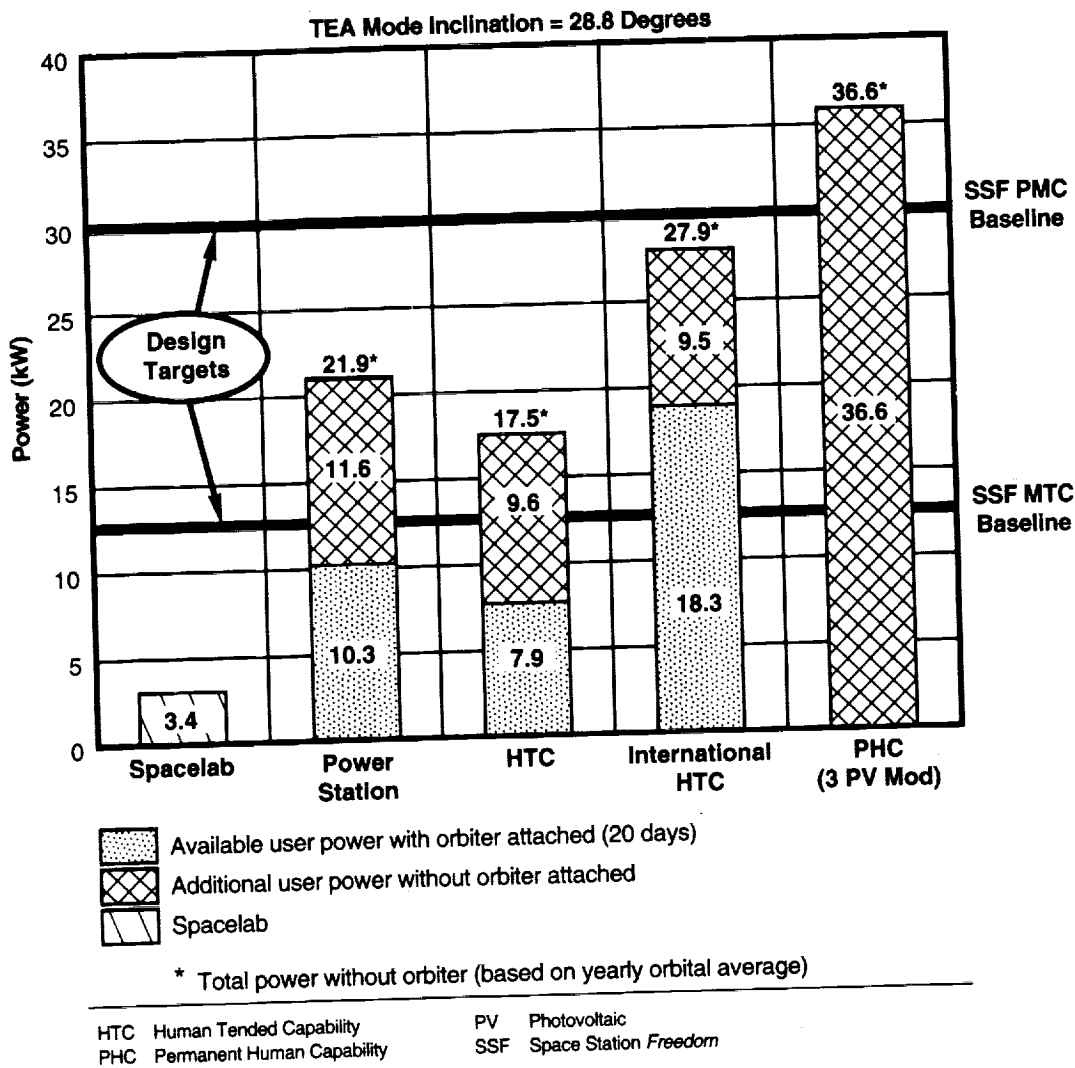

Figure 35.—Option A-2 available payload power comparison.

tasks that the Mobile Servicing System has to accomplish, have been coordinated with the Canadian Space Agency to establish the technical feasibility of the Option A design. A simplified version of the Mobile Transporter may be added to the Option A design during implementation, should technical justification warrant.

Likewise, changes in the thermal and electrical power interfaces between the NASA elements and the Attached Pressurized Module have been coordinated with the European Space Agency for technical feasibility. The result of this coordination was incorporation of the primary power feedthrough and thermal control heat exchangers on the Common Core/Lab module, which allows the European Attached Pressurized Module to be mated to the station without any planned extravehicular activity. This interface change is considered beneficial by the European Space

Agency and results in a very minor technical impact for the Common Core/Lab. Similar thermal interface changes were made for the Japanese Experiment Module. Additionally, the Option A data management system design does change the data management system interface with the European Attached Pressurized Module and the Japanese Experiment Module. However, both partners agree that the resultant hardware and software interfaces are simpler, and thus beneficial in that respect. Further review and coordination with both partners is required before interface definitions are fully established.

The category of "location/orientation" has minor impacts identified for both the Japanese Experiment Module and the Attached Pressurized Module. The orientation of these modules are slightly changed in Option A from the *Freedom* configuration, since the flight mode is changed from a local

Table 12.—Summary of Option A impacts on International Partner Memorandums of Understanding.

International Partner Impact Category	Canadian Space Agency (CSA)	European Space Agency (ESA)	National Space Development Agency of Japan (NASDA)	Italian Space Agency (ASI)
Utilization/ Payload Resources	Slight reduction in payload volume. Slight reduction in payload available power and data services.	Slight reduction in payload available power and data services.	Slight reduction in payload available power and data services.	Slight reduction in payload volume. Slight reduction in payload available power and data services.
Attachment Interface	U.S.-provided mobile transporter eliminated. Method of attachment of CSA's SSRMS has changed.	Core interface provisions by NASA Laboratory to APM. Slight impact from DMS simplification.	Slight impact from DMS simplification. Core thermal provisions by NASA laboratory to JEM.	No impact
Location/ Orientation	No impact	No impact	*	No impact
Schedule	Delivery schedule for CSA elements has been relaxed.	Delivery schedule for ESA elements remains unchanged.	Delivery schedule for NASDA elements remains unchanged.	U.S. will exercise option for Mini-Lab. MPLM's increased by 4 racks. Provide a new closet module. Provide an additional MPLM.

* Occasional reorientation of the space station assembly to maximize power generation

APM Attached Pressurized Module
DMS Data management system

MPLM Mini-Pressurized Logistics Module
SSRMS Space Station Remote Manipulator System

vertical/local horizontal mode in *Freedom* to the arrow mode in Option A. Because of this orientation change, the Japanese Experiment Module velocity vector has changed from a direction parallel to the space station's centerline to a direction perpendicular to it. However, it should be noted that the external viewing ability of both the Japanese Experiment and the Attached Pressurized Module has been preserved. For example, the Japanese Experiment Module's Exposed Facility remains oriented for nadir (i.e., Earth) viewing. The thermal control heat exchangers for the Japanese Experiment Module have also been moved to the Common Core/Lab. Again, these proposed changes have been coordinated with the international partners.

The delivery schedule for the Canadian Space Agency and Italian Space Agency elements has been relaxed, whereas the schedule for the Japanese Experiment Module and the Attached Pressurized Module remains essentially unchanged (the slight delay in the Attached Pressurized Module delivery seems acceptable to European representatives). The previously negotiated agreement with the Italian Space Agency to provide two Mini-Pressurized Logistics Modules and an optional mini-lab will have to be modified to increase the volume of the Mini-Pressurized Logistics Modules by four racks and to exercise the mini-lab option. In addition, it

seems appropriate to ask the Italian Space Agency to provide two additional stretched Mini-Pressurized Logistics Modules, one of which will be used as a closet module at Permanent Human Capability. All five elements will have increased volumes of four racks compared to the current Mini-Pressurized Logistics Module. Because of these increased requirements on the Italian Space Agency, the Italian Space Agency/NASA Memorandum of Understanding may have to be renegotiated.

The Option A station configuration preserves the missions of elements provided by the international partners and, with minor exceptions, preserves their elements' hardware and software interfaces to the NASA elements. For instance, International Standard Payload Rack interfaces, as specified in SSP-41002, *International Standard Payload Rack to NASA/ESA/NASDA Modules Interface Control Document*, are unchanged with the exception of modification to the data interface. The changes required in the other multilateral interface control documents are similarly small in scope, preserving to the maximum extent the existing *Freedom* interfaces. Where interfaces have been revised, significant effort has been made to ensure that the revised interface is simpler or otherwise improved over the *Freedom* design.

Growth Capability

The logical growth of the space station from the Permanent Human Capability phase would involve the increase of several of the most valuable resources the space station possesses—crew time, power, volume, and other resources. Crew time can be increased several ways, including increased automation, decreased maintenance, or increased crew size. The first two methods can be worked with the four-person station. Also, the basic station has an environmental control and life support system sized for a crew of eight people, so crew increases could be accommodated and this system would support additional crew volumes for longer duration. If long term larger crew sizes require growth of the space station pressurized volume, the Option A design, being a modular design like *Freedom*, will lend itself well to growth. The first module to be added would be a second habitation module, which would be followed by a second U.S. laboratory module and a fourth power array set, which would provide the additional 20 kilowatts of power needed to support the additional capability provided by the new modules.

The second habitation module would provide the crew with a new “quiet” module that contains sleep compartments for eight, a second galley, a second toilet, a window, a second shower, additional stowage, and additional refrigeration/freezer capability. The new laboratory would increase the number of experiment slots for the user community.

The growth of Option A-1 would be accomplished by placing the two new common modules on the port and starboard radial ports of the habitation module and mounting the displaced assured crew return vehicle and the airlock on the radial ports of the new modules. For both options, the fourth power array would be added to the port side of the truss in the same fashion as the third array was added to the starboard side. (Option A-2 would also position the two new modules on the port and starboard radial ports of the hab and the displaced assured crew return vehicles would then be placed on the radial ports of the new modules.)

Scars required to accommodate the growth modules, including utility hook-ups (e.g., power, thermal, data management system, etc.) will be provided. The berthing mechanisms are already in place to provide the structural interface for additional modules. The scars required to add the fourth array set include a spacer truss (similar to S5) for structural interface and the associated utility connections.

Potential Cost Savings Features

The following Option A design approaches resulted in cost savings relative to Space Station *Freedom*:

- Delete five truss sections on Option A-1; delete three truss sections on Option A-2.
- Use the common modules instead of modules and nodes; use a “core” module outfitting approach for the lab.
- Delete the battery charge/discharge unit, and the direct current switching unit, and the large rotary alpha joint.
- Delete the two-phase thermal control system.
- Simplify the atmosphere control and supply, and the temperature and humidity control system.
- Use Russian equipment to close the oxygen loop.
- Delay the airlock until Permanent Human Capability, and use a smaller airlock.
- Use the stretched Mini-Pressurized Logistics Module, and delete the United States pressurized logistics module.
- Delete the Mobile Transporter, replacing it with a small, simple cart and monorail; utilize the “inchworm” capability for Space Station Remote Manipulator traverse.
- Use the Bus-1 to provide all guidance, navigation, and control, and propulsion functions on Option A-1.
- Simplify data management system to a multiplexer/demultiplexer-based/1553B data bus using a simplified table-driven software architecture.
- Reduce audio and video components.
- Reduce the orbital replacement units by about 30 percent.

In addition to the above design changes, several programmatic and management changes are incorporated:

- Consolidate Level I/II management to a strong Level I.
- Use a single prime contractor with major subcontractors.
- Streamline operations for operations era.
- Simplify all interfaces due to reduced number of elements and simplified data management.

Notable features of Option A which should result in continuing cost saving features for users and yearly operations include:

- A significantly simplified data management system.
- Simplified management and interfaces.
- Simplified operations approaches on the ground and for flight planning.
- Fewer orbital replacement units.

Transportation

Shuttle

Shuttle performance data used in this report are listed in Table 13. These data are for a 220 nautical mile circular orbit, while protecting the shuttle program manager's reserve of 3,500 pounds. The data shown include rendezvous capability.

Table 13.—Shuttle performance data.

28.8 Degree Inclination	51.5 Degree Inclination
• 37,800 lb with RSRM	• 25,000 lb with RSRM
• 45,300 lb with Al-Li ET	• 32,500 lb with Al-Li ET
• 47,800 lb with ASRM	• 35,000 lb with ASRM
	• 42,500 lb with ASRM + Al-Li ET

Al-Li ET Aluminum lithium external tank
 ASRM Advanced solid rocket motor
 lb Pounds
 RSRM Redesigned solid rocket motor

Preliminary assessments indicate that the orbiters used to assemble Option A may create a plume impingement issue at certain phases of the concepts. Resource estimates have been included for orbiter thruster modifications for this eventuality. Alternate, less costly potential solutions have also been defined and are under study.

The orbiters used with the station will require extended duration orbiter modifications for longer stays at the space station (20 or more days). This study assumed a 20-day maximum orbiter stay-time because of crew limitations, and the orbiter modifications and fitout currently planned for this capability will readily suffice.

External airlocks with docking adapters will also be required for all orbiters. No advanced solid rocket motor or modified external tank will be required at 28.8 degrees, but either would provide significant benefit. A converter is required on the orbiter to convert station power from 160 volts direct current to 28 volts direct current when the orbiter is attached to the space station and using station power.

Assured Crew Return/Soyuz

Two Russian Soyuz spacecraft will be utilized for the assured crew return vehicles. Both spacecraft will be launched on a single shuttle flight.

Spacelab

During the Power Station phase of Option A buildup, the Spacelab (installed in the orbiter payload bay) is viable as a substitute on-orbit research lab to accommodate up to eight equivalent double racks of microgravity materials processing, life sciences, and other science experiments for extended operations of up to 30 days, subject to crew medical limitations—currently estimated to be 20 days per mission in this time frame—or possibly longer with some compromises. These orbiter/Spacelab flights would utilize the early station elements primarily as a source of power and attitude control. The orbiter and Spacelab together would provide all other necessary functions required to operate payloads.

Likewise, the Spacelab igloo/pallet train installed in the nadir-oriented orbiter payload bay could provide meaningful flight opportunities for Earth viewing, as well as limb-viewing investigations during the Power Station phase of Option A buildup. In addition, similar flight opportunities will be available during later buildup phases to again accommodate Spacelab pallet-mounted viewing instruments.

Spacelab pallets and mission-peculiar experiment support structures are viable orbiter payload bay carriers for transporting most attached payloads being considered for Space Station *Freedom*.

Specific Operations

Flight Operations

The flight operations approach for Option A is focused on safe and effective utilization of the space station as it evolves and grows. The character of Option A operations is consistent with the innovative operations concepts recommended by the Operations Phase Assessment Team II as described in their basic report dated April 23, 1993.

The Power Station configuration provides an early capability for a shuttle with Spacelab to dock and receive power for extended payload operations of 20 days. No space station unique ground facilities will be required to conduct these orbital operations. The Control Center Complex at Johnson Space Center will support the mission operations while the payload operations will be supported from the existing Payload Operations Control Center at Marshall Space Flight Center. Minimal ground support will be required between shuttle visits to maintain station systems and operate attached payloads.

Human-tended operations can begin with the addition of the Common Core/Lab. Pressurized payloads can begin to conduct long duration investigations. Astronauts will periodically visit the station on utilization flights of up to 20 days, and telescience operations can continue between shuttle visits. Systems operations will be focused at the Space Station Control Center, while the Payload Operations Integration Center will begin to support station utilization by the payloads.

The Japanese Experiment Module, the European Space Agency's Attached Pressurized Module, and the Japanese Experiment Module's Exposed Facility will provide increased international payload accommodations. Utilization flights will continue to provide payload outfitting and crew support. The shuttle will continue to provide some crew accommodations. Ground support of international partner payloads will be conducted from international partner locations.

The Permanent Human Capability configuration will provide for safe, long duration crew operations through the addition of the Soyuz assured crew return vehicles, the Common Module/Hab, airlock, and cupola. The operations emphasis will be on utilization activities with continued logistics and maintenance support. Additional station evolution can also be supported.

Ground Operations

The utilization of Bus-1 and Bus-1 ground support equipment in Option A-1 will not change the functional operations to be performed at the launch site. The assumption of "hands on" responsibility for Bus-1 processing by Lockheed and Kennedy Space Center in a "host" role is a departure from past space station planning, in which Kennedy Space Center has "hands on" responsibility for all U.S. space station elements. Under the current assumptions for Option A-1, Lockheed will perform the Bus-1 post-delivery verification test in the Space Station Processing Facility. Kennedy Space Center will then perform Bus-1-to-space station physical integration, functional interface demonstration tests, and simulated space shuttle interface verification tests, with Lockheed support for Bus-1 activities. After these activities in the Space Station Processing Facility, Bus-1 will be transported to a hazardous processing facility for propellant loading by Lockheed. After propellant loading, Bus-1 will be installed in a canister for transporting to the launch pad and installation into the space shuttle for launch. As more data becomes available from the Bus-1 program, allocation of responsibilities between Lockheed and Kennedy Space Center may need to be revised.

Pre-launch and post-landing operations for Option A-2 are reduced, but not functionally different than those planned for Space Station *Freedom*.

Logistics and Utilization Approach

Logistics and utilization flights supply the experiments and material required to utilize and maintain the space station. Delivered supplies include crew systems (food, clothing, etc.), user items (experiments, samples, etc.), spares (maintenance items), and fluids (oxygen, propellant, etc.). Utilization flights occur during the space station assembly phase and mark the beginning of payload crew operations. Logistics and experiments are manifested on three different logistics carriers which are then placed in the orbiter payload bay for delivery to the station. Pressurized cargo is delivered in a stretched version of the Mini-Pressurized Logistics Module which is designed to carry 12 racks (the current Mini-Pressurized Logistics Module from the Space Station *Freedom* program carries 8). The racks are swapped on orbit; used racks are returned to Earth. The Unpressurized Logistics Carrier accommodates a wide variety of items from cryogenic fluid bottles to unpackaged spare parts.

For Option A-2, propellant is delivered in the propulsion modules, which are basically unitized propulsion systems that are refilled and refurbished on the ground and cycled back to the station. Option A-1 receives propellant resupply with replacement Bus-1's. The Unpressurized Logistics Carriers and propulsion modules are the designs as used by the *Freedom* program.

The outfitting, utilization, and logistics flight schedule/manifests for the Option A-1 and A-2 assembly phases is depicted in Table 14. The data include usable payload for science and any other hardware or consumables that are required by the station, but the majority of each utilization flight is payload-related. Should assembly cease at any phase, the shuttle will fly as often as possible to maximize utilization of the station.

The Option A schedule shows the availability of the advanced solid rocket motor in 2001, early in the Permanent Human Capability phase. Logistics scenarios are discussed below for this phase using this motor.

At 28.8 degrees inclination, both Options A-1 and A-2 use the 12 rack Mini-Pressurized Logistics Module for four flights (carrying two modules on one of the flights), co-manifesting unpressurized cargo (cryogenic oxygen and nitrogen and/or attached payloads and spares) on three of these flights. Every two years, a fifth flight is required to carry a replacement Bus-1 (or propulsion modules for Option A-2). If the advanced solid rocket motor were not available, the number of flights would increase by about one per year. Using aluminum lithium external tanks and the advanced solid rocket motor would probably not be fully useful here unless the orbiter were modified to allow full use of this capability; if this were done, the number of logistics flights required would be about 3.5 per year.

At 51.6 degrees inclination, the 12 rack Mini-Pressurized Logistics Module is carried five times (co-manifested with unpressurized cargo on all flights), and unpressurized cargo flies on a sixth flight. Every two years a replacement Bus-1 flies as a seventh flight (or propulsion modules, in Option A-2, fly with unpressurized cargo on the sixth flight). The addition of aluminum lithium tanks would reduce the logistics flights by about one per year. Using neither the advanced solid rocket motor nor the aluminum lithium external tank would increase the logistics flights to about 9.5 per year for Option A-1 and 9 per year for Option A-2, and would require significant off-loading of Bus-1 (A-1) propellant; this is not a realistic case.

Maintenance/Spares Approach

The maintenance philosophy for Option A is the same as Space Station *Freedom*, which is maintenance by removal and replacement of orbital replacement units. Internal maintenance, (inside the pressurized modules), is performed by the crew; external maintenance is performed by robotics,

extravehicular activity, or cooperative extravehicular activity and robotics. Orbital replacement unit spares will be carried up by the shuttle on an as needed basis prioritized by criticality. At Permanent Human Capability, the most critical and frequently replaced orbital replacement units will be stored on the station.

The Option A plan and approach for external maintenance remains the same as *Freedom*; however, the amount of external maintenance is reduced by approximately 25 percent. The maintenance backlog during assembly is reduced approximately 70 percent. The backlog reduction is attributed to the insertion of several utilization flights between assembly flights, making available more external maintenance resources during assembly phases. The steady state maintenance reduction is a result of hardware deletions and system simplifications from the *Freedom* baseline. The maintenance concept relies on robotics to solely perform nearly half the external maintenance. The remaining maintenance will be accomplished using extravehicular activity. Although the extravehicular activity dual rail cart and the Mobile Transporter have been deleted, each has been replaced with viable alternatives: the monorail cart and the robotics "inch-worm" mobility approach. Although the inch-worm approach will slow down the transport of the robotics, the increased time can potentially be off-loaded to an operator on a ground control station. The Option A extravehicular activity system and robotics system designs both support the Option A external maintenance concept. Additional studies may indicate a need for continuing to utilize the Mobile Transporter.

Internal maintenance requirements for Option A were compared to similar results for the baseline design. For Option A, the total number of replaceable items was reduced by about 25 percent. This resulted in a 40 percent reduction in internal maintenance crew-hours per year compared to the baseline design.

Option A Unique Facilities/Ground Support Equipment

For Option A-1, Bus-1 is planned to be processed using its own ground support equipment in Kennedy Space Center facilities. Therefore, the Payload Spin Test Facility-Replacement will not require outfitting to process space station propellant modules. The Payload Spin Test Facility-Replacement or another Kennedy Space Center facility may require modifications to accommodate the Bus-1 and ground support equipment. The facility selected for fueling the Bus-1 may require unique Bus-1 transportation and rotation ground support equipment.

Option A-2 will utilize the facilities and ground support equipment planned for Space Station *Freedom*, with adjustment for space station changes in systems and manifest.

Table 14.—Utilization, logistics, and outfitting flights for Option A-1 and A-2 at 28.8 degrees inclination, standard external tank, no advanced solid rocket motor.

Flight	Weight (lb.)*		Item
	Pressurized	Unpressurized	
UF-1	<input type="checkbox"/> 10,400 14,700	5,770 <input type="checkbox"/> 5,830	Spacelab Racks Spacelab Long Module Overhead User Available
UF-2		11,060 3,646 2,646 <input type="checkbox"/> 19,348	O2/N2 Cryo Carriers ULC Tare Weight Overhead User Available
AF-4A	7,200 <input type="checkbox"/> 5,000 8,700	4,174 (2,134) 3,661 (0) <input type="checkbox"/> 6,965 (12,666)	6 U.S. Lab Outfitting Racks 5 User Consumables Racks 12 Rack MPLM Tare Overhead SSRMS User Available
UF-3	3,600 <input type="checkbox"/> 8,000 8,700	2,134 <input type="checkbox"/> 13,266	3 U.S. Lab Outfitting Racks 8 User Consumables Racks 12 Rack MPLM Tare Overhead User Available
LF-1		29,310 (22,080) 3,800 0 (2,089) 2,098 (5,254)	Bus-1 (Propulsion Modules) Cupola Short Truss Overhead
AF-7A	6,000 6,000 <input type="checkbox"/> 1,000 8,700	3,174 5,530 3,646 <input type="checkbox"/> 1,650	5 JEM System Racks 5 JEM ISPR's 1 User Consumables Rack 12 MPLM Tare Overhead Cryo Carrier ULC User Available
LF-2	<input type="checkbox"/> 6,000 8,700	11,060 3,646 3,174 <input type="checkbox"/> 3,120	6 User Consumables Racks MPLM Tare O2/N2 Cryo Carriers ULC Tare Weight Overhead User Available
AF-8A	10,800 <input type="checkbox"/> 2,000 8,700	2,134 <input type="checkbox"/> 12,066	9 APM Outfitting Racks 2 User Consumables Racks MPLM Tare Overhead User Available
UF-4	<input type="checkbox"/> 13,200 8,700	2,134 <input type="checkbox"/> 11,666	11 User Racks MPLM Tare Overhead User Available

AF Assembly Flight
 APM Attached Pressurized Module
 JEM Japanese Experiment Module
 ISPR International Standard Payload Rack
 LF Logistics Flight
 MPLM Mini-Pressurized Logistics Module
 SSRMS Space Station Remote Manipulator System
 UF Utilization Flight
 ULC Unpressurized Logistics Carrier

User item () A-2

*1,800 pound Space Station *Freedom* Program margin is not held in reserve.

Notes: • Terminology for "assembly," "utilization," "logistics," etc., is compatible with SSF.
 • A-2 is the same as A-1 unless noted otherwise.

Technology Requirements and Opportunities

Option A utilizes largely Space Station *Freedom* or *Freedom*-derived designs and technologies. These provide advancements in performance, reliability, efficiency, etc., over older NASA technologies embodied in shuttle and Spacelab hardware. Option A incorporates improvements in technologies in the areas of improved environmental control and life support systems, greater automation (on orbit and on the ground); telerobotics (remote control), improved robotics, improved reliability/lifetimes, enhanced computers/digital systems/software, and improvements in other areas over Spacelab/shuttle systems. At the same time, Option A utilizes less complex technologies than *Freedom* in a few areas, such as a single phase instead of a dual phase thermal control system, a multiplexer/demultiplexer-based data management system that eliminates fiber optic networks and reduces data processing complexity, and an electrical power system without an alpha joint. Such choices were made to enable reductions in cost, risk, and schedule time.

Russian technologies incorporated into Option A include the Soyuz vehicle as an assured crew return vehicle and the potential use of Russian oxygen loop closure equipment at Permanent Human Capability. Commercial technologies incorporated include laptop computers for workstations and some extravehicular activity tools.

Opportunities exist in Option A for technology advancement by upgrading technologies in an evolutionary fashion over time. Prime high-leverage areas for technology advancement exist in the environmental control and life support system area by closing the oxygen loop. Additionally, there are potentials for increasing automation, using more efficient robotics/telerobotics, and selected subsystem upgrades.

Option A provides internal and external payload accommodation for advanced-technology experiments and research in various sciences (including commercial participation). Long-duration manned space missions provide advances in life sciences technologies, such as: (1) advancement of human skills, techniques, and knowledge base, and (2) improved data on human physiological, psychological, and social aspects of space habitability.

Top Level Cost

Cost inputs have been developed for the respective A-1 and A-2 design options. These costs were then made consistent for comparison purposes for all options by the Station Redesign Team, but are not included in this report. Option A costs are believed to be sound estimates based on a very good technical understanding of the system design, much mature hardware, and reasonable cost reviews. Design approaches and adjustments were accounted for at the subsystem and subassembly levels, with integration and other cost-wraps added. Resulting costs have been defined for Option A-1 and A-2 at the Permanent Human Capability phase, and for three intermediate potential stopping points.

The Option A designs each utilize a significant amount of systems that are being developed in the Space Station *Freedom* program. Therefore, the Option A team used the latest *Freedom* estimates from the April 9, 1993, control package and developed a cost-estimating model that estimates costs at the subsystem level for all station-related hardware. Many subsystems in both Options A-1 and A-2 are estimated using this model.

Reductions in costs are being taken to reflect the management, interface, and contracts streamlining. The overall effect of these reductions is in the neighborhood of 10 percent of the total program cost, and these reductions will require agency-wide commitment to achieve.

Subsystem costs are based on the inputs provided by the Option A technical team. The cost of those components that are deleted are "zeroed out," while those components and subsystems that are simplified are reduced accordingly. Where partial or full redesign was involved, the degree and complexity of the design changes have been costed.

For Option A, the Operations Phase Assessment Team estimated the cost for the Operations Utilization and Capability Development and the operations era. The Shuttle Program Office (Level II) had the responsibility to provide the necessary cost requirements for integration of the station into the shuttle cargo bay and the orbiter docking system. Cost estimates were included for these transportation requirements. Cost estimates for Bus-1, the assured crew return vehicle, and other elements were made based on design modifications, new design, and unit cost estimates made interacting with the industry and NASA Headquarters.

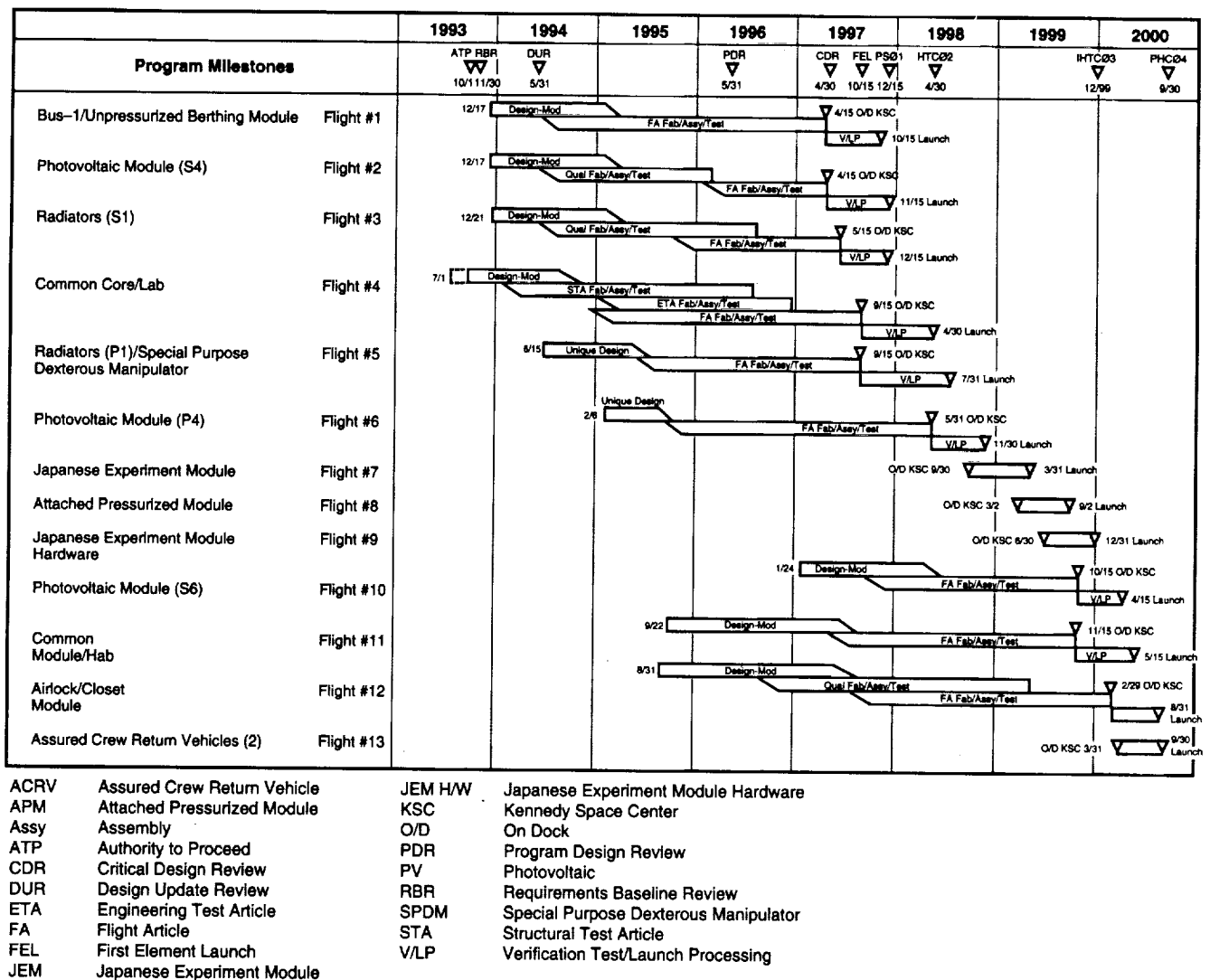

Figure 37.—Option A-1 schedule.

to proceed. In the spring of 1994, a Design Update Review is planned, to review modifications to current Space Station *Freedom* program hardware that has already undergone a Critical Design Review. Requirements and designs will be frozen at the completion of this review. A separate Program Design Review and Critical Design Review will be conducted for the Common Module/ Hab and other elements which have not been through the design review process (i.e., hardware on assembly flights 11 and 12).

For hardware common to the current program, the *Freedom* network logic relationships and time estimating relationships have been largely adopted in developing the schedules. A time span for redesign of modified *Freedom* hardware has been included, as appropriate.

A critical path analysis and schedule risk assessment have been conducted, and are included in the reference material. The development schedules are generally success-oriented;

however, the schedule risk is judged to be acceptable. A delay in the first element launch of Option A relative to Space Station *Freedom* has, in fact, somewhat mitigated the risk inherent in the current space station program. In particular, the time between completion of the Common Core/Lab qualification testing and the completion of flight article acceptance testing has increased about 6 months over the *Freedom* baseline program.

The availability of the shuttle orbiter fleet to accommodate the proposed assembly sequence has been examined. This analysis assumes that orbiters OV-103, OV-104, and OV-105 are modified for capability to perform the assembly and utilization missions. This schedule includes the Kennedy Space Center processing time, on-orbit mission time, and the planned periodic orbiter maintenance at Palmdale, California. The conclusion is that the three modified orbiters can accommodate the planned assembly and utilization missions.

Summary—Attributes and Issues

Assessments completed in this study period indicate that Option A (either A-1 or A-2) provides a space station which is smaller, less complex, and less expensive than the current baseline Space Station *Freedom*. It is expected that Option A could be in a cost range potentially affordable with permanent human capability. Option A has only 16 assembly launches, an extensively simplified data system, and other deletions or simplifications, compared to *Freedom*; it is simpler and easier to integrate, test, and assemble on orbit, and requires fewer extravehicular activities. At the higher end of its range, it offers most of the same capabilities as *Freedom*, and has some improvements in performance, although it has less total pressurized volume, some compromises in power, and fewer payload racks. Major improvements have been made in a balanced manner across management, integration, design/hardware, and operations, which should provide significant cost reduction.

Option A provides a very good microgravity environment and good accommodation of life sciences payloads, including centrifuge accommodations. Many opportunities and locations exist to mount instruments for viewing in the four primary directions of interest (including those of interest to Earth sciences and astronomy/astrophysics payloads). International partners are afforded a high degree of accommodation, approximately equivalent to today's baseline program.

Option A uses a modular buildup approach, launching with the space shuttle, which minimizes cost and risk of development and launch. Three intermediate "plateaus" of operation are provided, allowing for effective user opportunities in the buildup sequence.

A number of utilization flights have been interspersed with assembly flights in the sequence, to enhance such utilization, but if cost or other major constraints dictate, these could be reduced for streamlining or acceleration of the buildup. If cost constraints limit the capability of the station, it could be optimized for improved operation at any of the plateaus, using them as three effective intermediate "stopping points"—Power Station, Human Tended, and International Human Tended plateaus. Modifications needed for such optimization have been identified. Continuing the buildup to Permanent Human Capability produces the most cost-effective station operation, and achieves a primary goal of permanent human presence on orbit.

Option A includes substantially simplified management interfaces and contracting; embraces streamlined operations and related capabilities; and deletes hardware elements such as the complex alpha joint, the two-phase thermal system, separate nodes and modules, the pressurized logistics module, and several truss sections; while significantly simplifying the data management system and selectively simplifying other subsystems. The concept provides excellent continuity and utilization of existing Space Station *Freedom* designs and hardware, as well as selected existing items from Spacelab/Space Transportation System, defense-related systems (Option A-1), Russian, and commercial systems. It is a sound, failure tolerant design approach with good margins and cost-effective capabilities. The primary issues are related to projected cost, compared to the potentially available budget. Additional work is needed to more fully understand Bus-1 and the Russian hardware, and to more completely develop the technical data, including cost.

Dr. Charles M. Vest President and Professor of Mechanical Engineering Massachusetts Institute of Technology	
Dr. Bobby Alford Executive Vice President and Dean of Medicine Baylor College of Medicine	Mr. Frederick Hauck President International Technical Underwriters
Mr. Jay Chabrow President JMR Associates	Dr. Lou Lanzerotti Chairman, Space Sciences Board National Research Council
Dr. Paul Chu Director, Texas Center for Superconductivity University of Houston	Mr. William Lilly National Academy of Public Administration
Dr. Ed Crawley Professor of Aeronautics and Astronautics Massachusetts Institute of Technology	Mr. Duane McRuer President Technical Systems, Inc.
Dr. John Fabian President and CEO ANSER	Dr. Brad Parkinson Professor of Aeronautics and Astronautics Stanford University
Dr. James Fain Deputy Chief of Staff for Requirements Headquarters, USAF Materials Command	Dr. Robert Seamans Former Deputy Administrator NASA
Dr. Edward Fort Chancellor North Carolina A&T State University	Dr. Lee Silver W.M. Keck Foundation Professor for Resource Geology California Institute of Technology
Dr. Mary Good Senior Vice President of Technology Allied Signal, Inc.	Dr. Albert "Bud" Wheelon Retired CEO Hughes Aircraft

Figure A-1.—Advisory committee on the redesign of the space station (Blue Ribbon Panel).

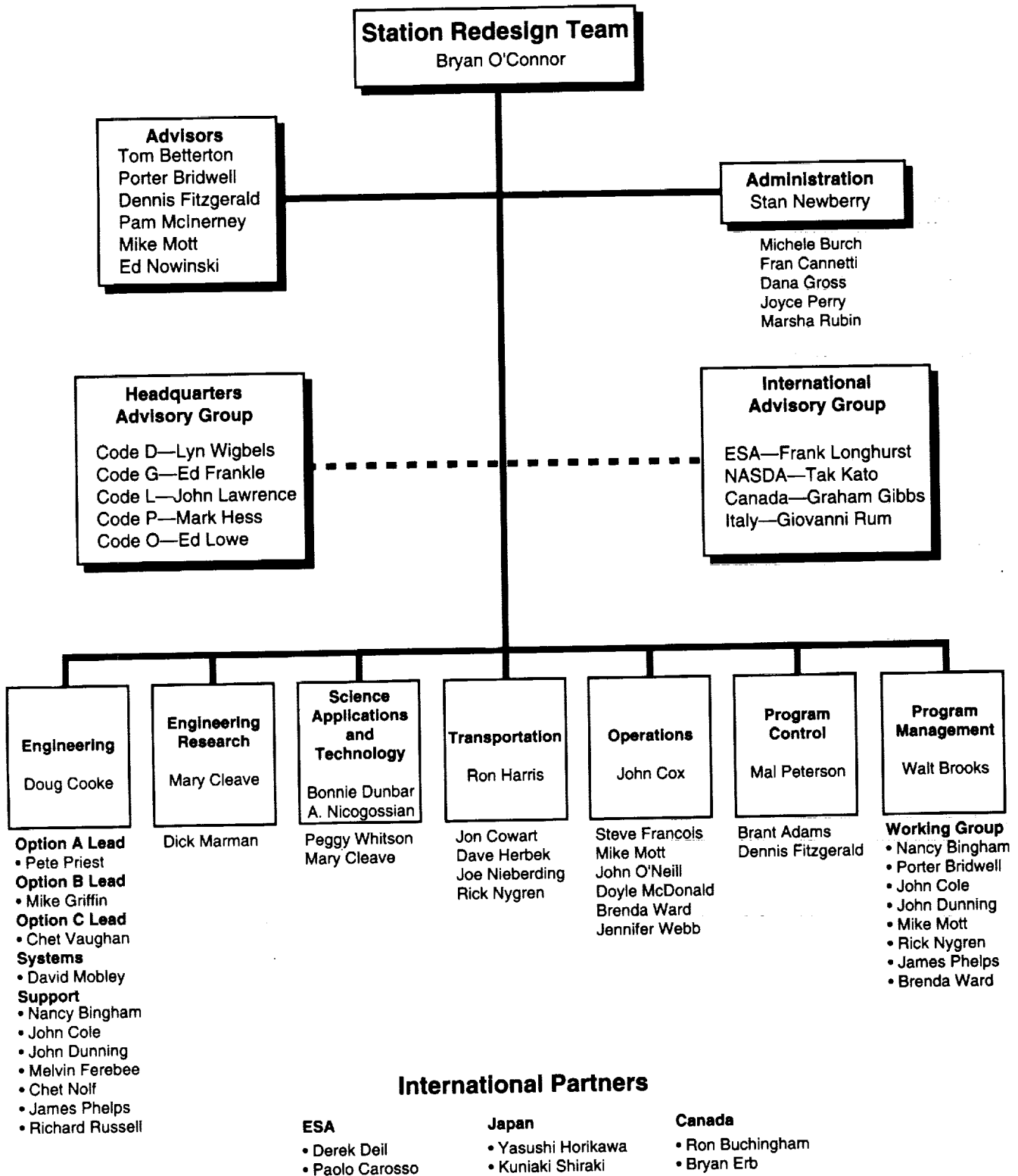

Figure A-2.—Station Redesign Team.

Bryan O'Connor Director NASA, Headquarters	Ed Frankle NASA, Headquarters	Ed Nowinski Central Intelligence Agency
Brant Adams NASA, Stennis Space Center	Graham Gibbs Canadian Space Agency	Rick Nygren NASA, Johnson Space Center
Rear Admiral Tom Betterton U.S. Navy (Ret.)	Mike D. Griffin, Ph.D. NASA, Headquarters	John O'Neill NASA, Johnson Space Center
Nancy Bingham NASA, Ames Research Center	Dana Gross NASA, Headquarters	Joyce Perry NASA, Headquarters
Porter Bridwell NASA, Marshall Space Flight Center	Ron Harris NASA, Headquarters	Mal Peterson NASA, Headquarters
Walt Brooks, Ph.D. NASA, Ames Research Center	David Herbek NASA, Headquarters	James Phelps NASA, Dryden Flight Research Facility
Ron Buchingham Canada	Mark Hess NASA, Headquarters	Pete Priest NASA, Marshall Space Flight Center
Michelle Burch NASA, Headquarters	Yasushi Horikawa, Ph.D. National Space Development Agency of Japan	Marsha Rubin NASA, Headquarters
Fran Cannetti NASA, Headquarters	Tak Kato, Ph.D. National Space Development Agency of Japan	Giovanni Rum Italian Space Agency
Paolo Carosso European Space Agency	John Lawrence NASA, Headquarters	Richard Russell NASA, Langley Research Center
Mary Cleave, Ph.D. NASA, Goddard Space Flight Center	Frank Longhurst European Space Agency	Joseph Shea, Ph.D. NASA, Headquarters
John Cole NASA, Marshall Space Flight Center	Ed Lowe NASA, Headquarters	Kuniaki Shiraki National Space Development Agency of Japan
Doug Cooke NASA, Johnson Space Center	Dick Marman NASA, Marshall Space Flight Center	Chet Vaughan NASA, Johnson Space Center
Jon N. Cowart NASA, Kennedy Space Center	Doyle McDonald NASA, Headquarters	Brenda Ward, Ph.D. NASA, Johnson Space Center
John Cox, Ph.D. NASA, Headquarters	Pam McInerney NASA, Headquarters	Jennifer Webb NASA, Kennedy Space Center
Derek Deil European Space Agency	David Mobley NASA, Marshall Space Flight Center	Peggy Whitson, Ph.D. NASA, Johnson Space Center
Bonnie Dunbar, Ph.D. NASA, Johnson Space Center	Mike Mott General Research Corporation	Lyn Wigbels NASA, Headquarters
John W. Dunning, Jr., Ph.D. NASA, Lewis Research Center	Stan Newberry NASA, Kennedy Space Center	Johnson Space Center Design Support Team
Bryan Erb Canadian Space Agency	Arnauld Nicogossian, M.D. NASA, Headquarters	Langley Research Center Design Support Team
Melvin Ferebee NASA, Langley Research Center	Joseph Nieberding NASA, Lewis Research Center	Lewis Research Center Power System Design Support Team
Dennis Fitzgerald Central Intelligence Agency	Chet Nolf NASA, Headquarters	Marshall Space Flight Center Design Support Team
Steve Francois NASA, Kennedy Space Center		

Figure A-3.—Station Redesign Team members.

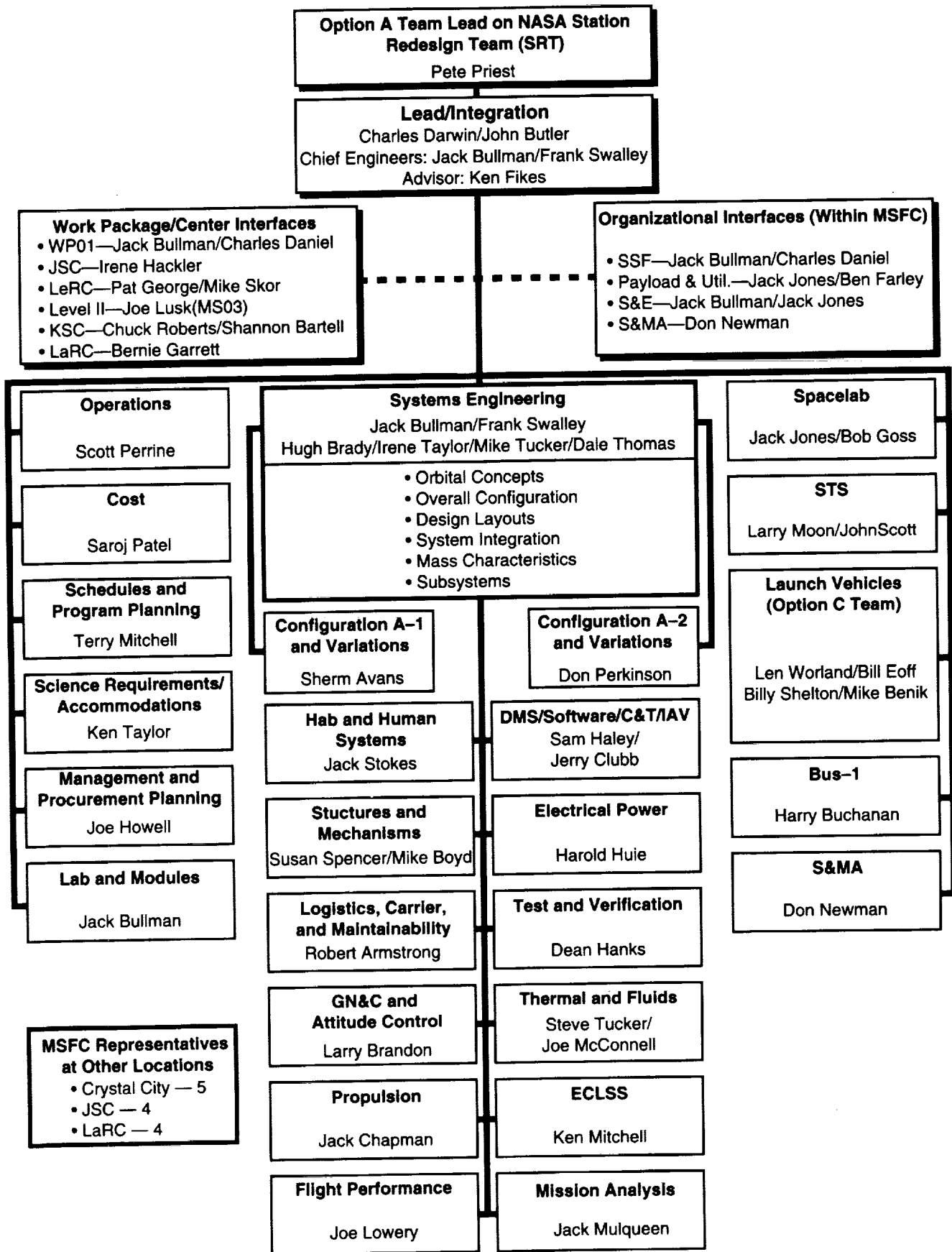

Figure A-4.—Option A station redesign study team.

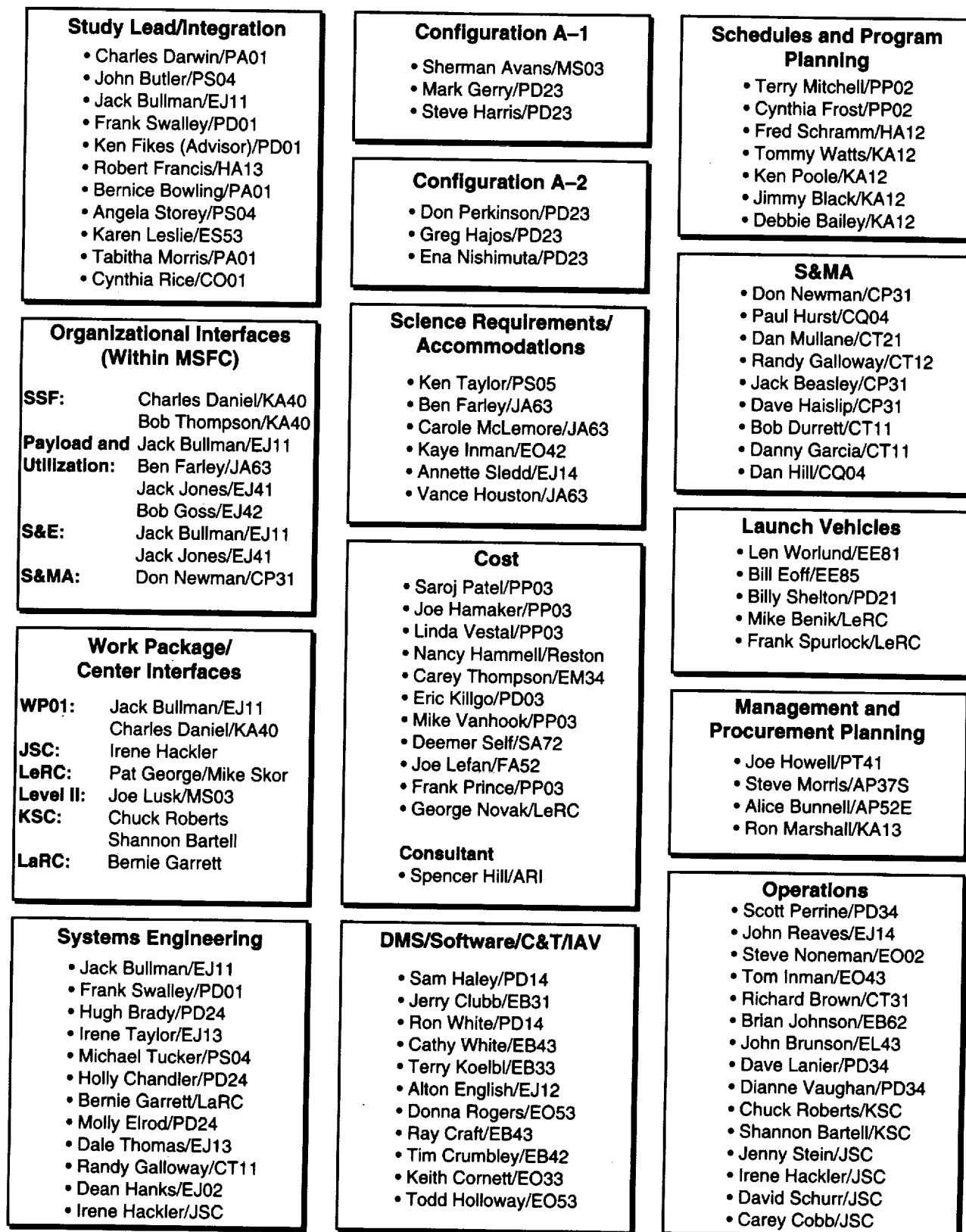

Figure A-5.—Option A station redesign support team members.

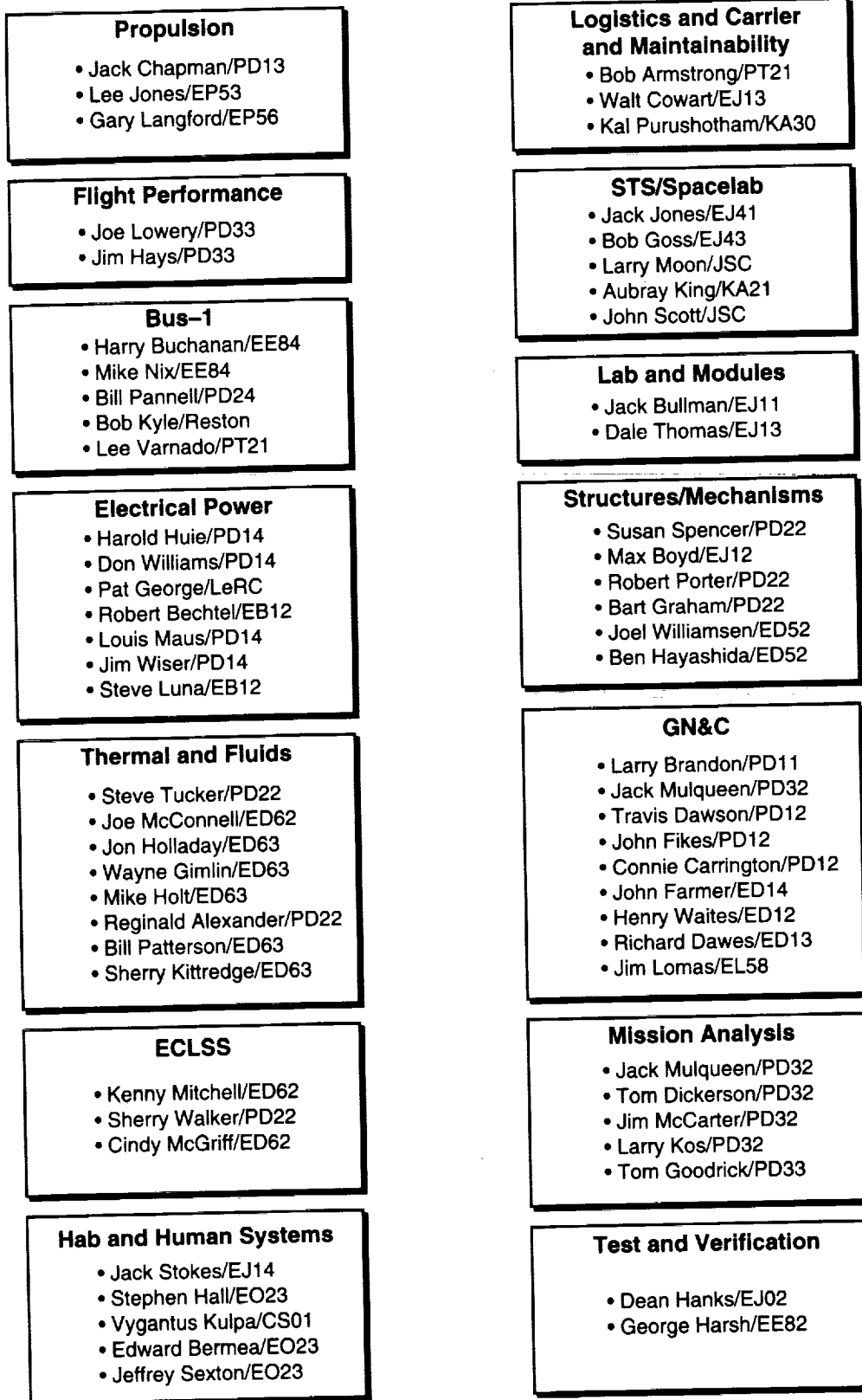

Figure A-5.—Option A station redesign support team members (continued).

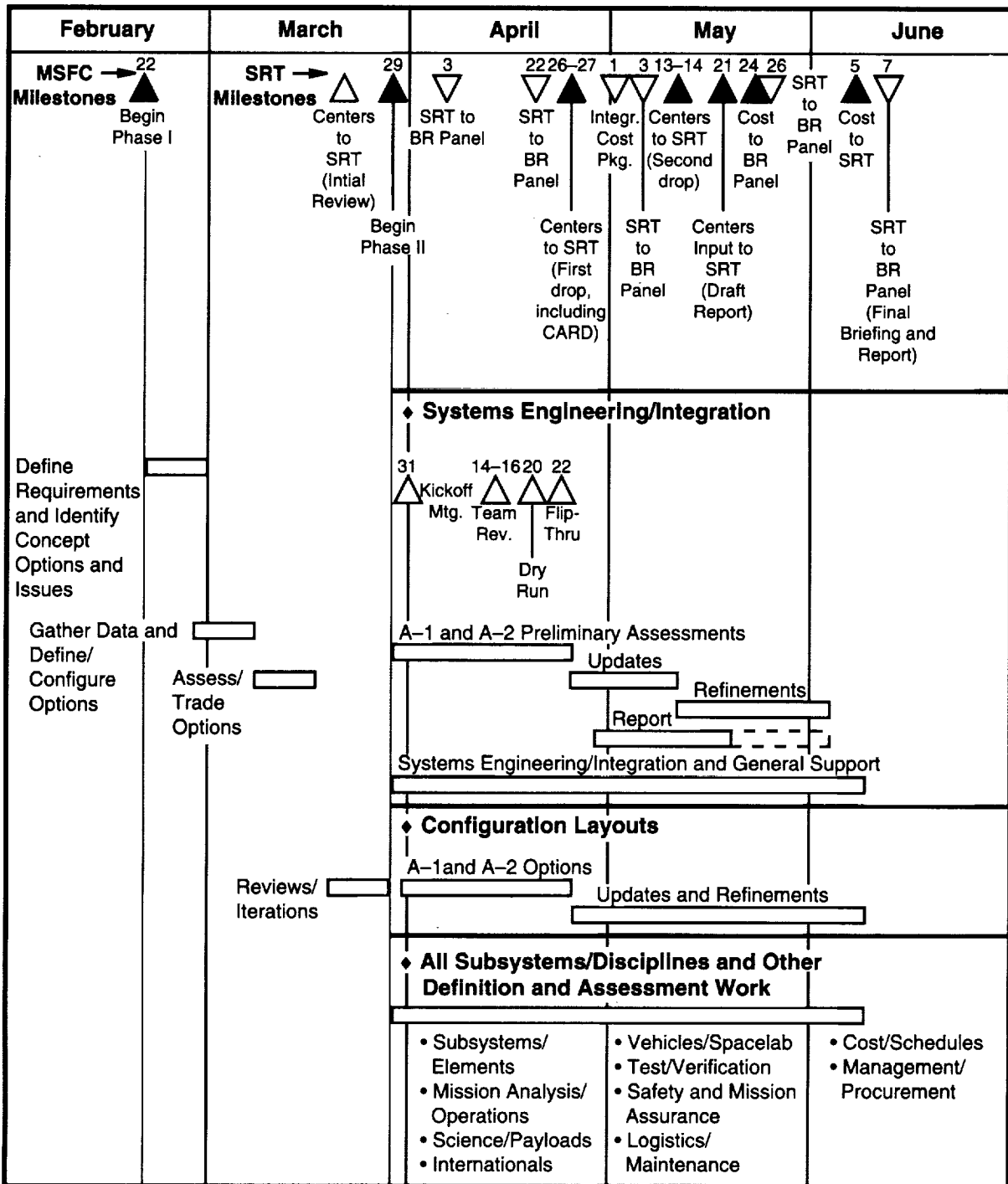

Figure A-6.—Option A station redesign study team schedule.

Appendix B

Design Requirements

Guidelines From the Administrator

All designs must:

1. Meet the budget
2. Demonstrate adequate (up-front) schedule and budget reserves
3. Have initial on-orbit research by 1997
4. Complete development by 1998
5. Have acceptable programmatic risk
6. Have acceptable technical risk
7. Have a 10-year on-orbit life (extendible to 15 years)
8. Include significant long-duration space research starting at Permanent Manned Capability (now called Permanent Human Capability)
 - High priority materials
 - High priority life science
9. Respect the commitment to the International Partners to the maximum extent possible
10. Stimulate technical fallout

Science, Technology, and Engineering Research Design Guidelines

All designs shall:

Crew

1. Provide the minimum science and engineering research requirement of 2 payload dedicated crew for 90 day increments beginning with Human Tended Capability.

Power

2. Provide 30 kW power for users when the International Partners are accommodated.
3. Provide a minimum of 12 kW continuous power to an individual payload located in the minimum acceleration area (0.707×10^{-6} g for 0.01 Hz to 0.10 Hz).
4. The external attach points should be provided with not less than 3 kW total, but available to all external sites.
5. Have 28 volt dc and 120 volt ac available to payloads; local conversion is acceptable.

Environment and Crew Health

6. Provide normoxic conditions, 21 percent oxygen, maximum 0.3 percent carbon dioxide.

External

7. Have not less than 4 external attach points (which include the International Partners' locations) with active cooling desirable.
8. Have a 10 mega-bits per second downlink capability for each external payload (may be phased).
9. Have uplink command capability for external payloads.
10. Locate external attach points for payloads in the following directions (in order of the priority):
 - Nadir (e.g., sensor development)
 - Ram/wake/port/starboard (e.g., engineering materials exposure)
 - Zenith (e.g., celestial viewing)

Data Processing

11. Have a payload data management and control computer for coordination of payload operations and data downlink (United States Lab only).
12. The science users will provide their own experiment control and display interfaces (United States Lab only).

Volume

13. Have no less than 35 cubic meters available to all users when the International Partners are accommodated, 13 cubic meters for payloads at Human Tended Capability (assume International Standard Payload Rack).

Microgravity Environment

14. Comply with the Space Station *Freedom* 1992 Program Definition and Requirements Document requirement for acceleration levels versus frequency and associated constraints.
15. Have an acceleration mapping system consistent with current Space Station *Freedom* baseline.
16. Have a vibroacoustic control plan which can be verified through a combination of ground modeling/testing and final on-orbit verification.

Communications

17. Have a video downlink:
 - Quality of single channel downlink not less than Orbiter/Spacelab
 - Video compression of at least 6 channels from Human Tended Capability
 - Video available during periods of untended operations
18. Have a total downlink capability of not less than 50 mega-bits per second in both tended and untended operations.
19. Have an uplink video of one channel, with medium fidelity required.
20. Have total uplink of:
 - Not less than 72 kilo-bits per second
 - Spacelab equivalent for stored program commands and transfer to Dedicated Experiment Processors
 - Available in both tended and untended operations
21. Have video interface and switching with not less than 4 payload video cassette recorders.
22. Have a data outage recorder with enough capability to capture downlink data with Loss of Signal to the users of not less than Spacelab at Human Tended Capability.

Resources and Support

23. Provide a nitrogen purge supply for furnaces, combustion facilities, etc.
24. Provide potable research water.
25. Provide non-hazardous experiment gas venting.
26. Provide an optical viewing window with:
 - At least one with nadir viewing, then, in order of priority:
 - Oblique (port or starboard)
 - Zenith
 - Not less than 20 inches in diameter
 - Location optimized for uncontaminated environment
 - 0.5 kW and data available at that location
27. Provide capability to change out payloads during the lifetime of the station.
28. Provide payload access to both air and water cooling.
29. Provide user access to the Space Station for samples, equipment, etc., with late access for launch at the launch site.
30. Provide users with logistical return of samples, equipment, etc., insuring that animals, refrigerated samples, etc., are returned to researchers in a reasonable time.
31. Have a caution and warning method for payloads adhering to a standard which shall be common among the users.
32. Provide human physiological baseline data collection capability (current orbiter/Spacelab capability is acceptable) at the landing site.

33. Include distributed science operations/training centers use distributed using commercial and NASA institutional audio, video, and data communications systems.
34. Accommodate the United States position: Integrated payload training should be consolidated at a single location.
35. Have a logistical supply environment (for research specimens) with pressure and power and late access.
36. Utilize small, task-unique payload modules and laboratory facilities which will be flown when needed and returned to Earth when not in use.
37. Have provisions for space, power, data, and other requirements (scars) available to expand subsystems in an evolutionary manner, including the capability for collecting performance data on subsystems during operations. Enough sensors should be available to provide statistically significant data.

Engineering Design Guidelines

All designs shall:

Safety Systems

1. Include station and crew survival functions which, as a minimum, are 2 fault tolerant (except during assembly and maintenance).
2. Include safety monitoring, emergency controls, and mission success functions which are 1 fault tolerant.
3. Have autonomous control for Station critical functions.
4. Include the capability for override of all autonomous functions which will be available onboard and on the ground.
5. Permit crew initiated manual overrides of time critical crew and Station survival systems.
6. Have emergency caution and warnings enunciated to the crew and may be on an independent path. It shall alert the crew of malfunctions which threaten crew or Station survival.
7. Include a fire detection and suppression capability.
8. Include an assured crew return capability at Permanent Human Capability.
9. Have a hazard analysis and containment process which adheres to *National Space Transportation System 1700.7B*.

Power System

10. Have continuous emergency power, to support Station survival and crew survival functions, available in any attitude.

Data Processing Systems

11. Provide that the Data Management System transport medium be durable and easily repairable on-orbit.
12. Sensors and measurements will be consistent with the operational concept.
13. Have core system functions partitioned such that the hardware and software for Station survival functions are decoupled from the hardware and software for all other Station functions.

Communications Systems

14. Have communications capability to vehicles, ground, and extra-vehicular activity.

Environmental Control and Life Support Systems

15. Maintain normoxic conditions of 21 percent oxygen and a relative humidity of 30 to 70 percent.
16. Have an environmental control and life support system sized to meet normal gas consumption and losses between logistic resupplies, plus the capability to repressurize volumes that may require it, during operations and contingencies.
17. Not contribute to space debris due to their waste management system.
18. Return solid waste to Earth.
19. Reprocess or safely dump liquid waste.

External

20. Keep the fluids in external components which handle fluids from freezing, or shall be designed to remain undamaged if the contained fluids are frozen.
21. Consider the preferred methods of external orbital replacement unit maintenance are, in order:
 - Robotics
 - Extra-Vehicular Activity
22. Have a thermal control system designed to operate without planned exterior component replacement for 10 years. However, all components will be designed for repair or replacement.

Propulsion

23. Have reboost capability.

General

24. Accommodate simultaneous dual orbiter mating.
25. Have the Station structure, solar arrays, radiators, attached payloads, and other exterior elements allow adequate clearance for the Orbiter's expected docking envelope. Other vehicles docking with the Station will be expected to conform with the orbiter's envelope.
26. Have accessibility of Space Station systems performance data by onboard applications and from the ground.
27. Reach United States Permanent Human Capability by the end of calendar year 1998.
28. Have a probability of no less than .9955 of surviving a micrometeoroid/orbital debris hit during the Station's 10 year life.
29. Maintain a capability for a 2 year orbit life independent of resupply.
30. Have safing features which can be selected, regardless of control failures, when using robotic devices to support extra-vehicular activity or other critical operations.
31. Have redundancy to protect the survival temperature of all robotic devices.
32. Include the capability that all interior compartments be able to be individually depressurized and repressurized by local control, from another compartment, or from the ground, as required.
33. Isolate all pressurized compartments when the crew leaves the Station.
34. Only plan operations to be performed in untended modes which have adequate hazard detection and control.

Special Note

All references to Space Station *Freedom* components (weight, power, volume, maintenance crew time, thermal, and logistics) shall be directly traceable to the March 1993 submissions (by the Work Packages and International Partners) of the above data to Space Station *Freedom* Level II Resource Margin Summary.

Operations Design Guidelines

All designs shall:

Safety

1. Have fail safe payload support systems.
2. Define the maximum altitude allowed by the radiation exposure limits of the crew when a crew is present.
3. Have safe haven capability.
4. Have consumables and system capacities that have sufficient margin to continue operations and endure a missed logistics resupply cycle without endangering the crew or Station.

Crew

5. Have a minimum crew size of three when the Station is operational.

Data Processing

6. Display Station and payload health, status, and safety data on-orbit.

General

7. Include an integrated logistics support concept.
8. Include an assembly plan.
9. Include a test and verification plan.
10. Utilize standardized tools and equipment necessary to analyze problems and to repair and modify process hardware which will be available for internal payload experiments.
11. Provide for safe disposal of the Station at the end of its useful lifetime.
12. Include an airlock.
13. Provide for a Mission Director and a Station Commander.
 - The Mission Director will be established on the ground and be responsible for:
 - Execution of mission objectives
 - Mission planning
 - Tasking
 - Allocation of priorities, resources
 - Flight planning
 - Resupply, rendezvous planning
 - Contingency operations
 - The Station Commander will direct on-orbit activities, and will be responsible for:
 - Health and safety of the crew
 - Integrity of the Station
 - Accomplishment of the missions and tasks assigned

Guidelines Derived From The Existing International Agreements

The below listed guidelines include those developed and agreed by the four Partners, as derived from the top level commitments undertaken by these partners in the Inter-Governmental Agreements and the Memoranda of Understanding. For completeness, certain agreements derived from the Memorandum of Understanding with the Italian Space Agency have also been incorporated. These guidelines, together with those developed in the United States, will constitute the total set of guidelines to be used in the initial definition of redesign options and the assessment of options throughout the redesign effort.

1. The technical and programmatic baseline of any option shall include the assembly of the Attached Pressurized Module, Japanese Experiment Module, Mobile Servicing System, and the Mini-Pressurized Logistics Module as well as the necessary resources to support their operations and utilization (i.e., the Attached Pressurized Module, Japanese Experiment Module, or Mobile Servicing System should not be associated with a growth configuration or planning).
2. The technical and programmatic baseline shall achieve Permanent Manned Capability (now called Permanent Human Capability) on a timeline agreed by all partners.
3. The schedule for the Mini-Pressurized Logistics Module development and the Attached Pressurized Module, Japanese Experiment Module, and Mobile Servicing System launch and outfitting shall not significantly deviate from current Space Station *Freedom* baseline.
4. A crew of 4 shall remain the minimum at Permanent Manned Capability (Permanent Human Capability).
5. A growth potential for a crew of 8 and 75 kW power shall be maintained.
6. The "new" on-orbit operational life requirement shall be counted from the time of completion of assembly, including the Attached Pressurized Module, Japanese Experiment Module, and Mobile Servicing System. On-orbit operational lifetime shall be coordinated amongst the partners.
7. The Space Station *Freedom* system requirements applicable to the Attached Pressurized Module, Japanese Experiment Module, Mobile Servicing System (through the Program Definition and Requirements Document/ Joint Program Definition and Requirements Document), and the Mini-Pressurized Logistics Module shall be kept to the maximum extent. Impact of deviations to be assessed and agreed by the management mechanisms provided by the Memoranda of Understanding.
8. Same for any already established technical interfaces and interface control documents between Space Station *Freedom*, the Attached Pressurized Module, Japanese Experiment Module, Mobile Servicing System, and the Mini-Pressurized Logistics Module, and to payloads.
9. Shuttle launch performances and interface requirements for the Attached Pressurized Module, Japanese Experiment Module, Mobile Servicing System, and the Mini-Pressurized Logistics Module shall not be modified.
10. In assessing the operations scenario and costs, proposed additional contributions from the international partners and Italian Space Agency's willingness to consider elevating the priority of the Mini-Lab shall be taken into consideration.
11. The Mini-Pressurized Logistics Module shall be considered the pressurized carrier to support initial on-orbit research capability. Significant uses of the Mini-Pressurized Logistics Module is to be envisaged once the development of the Space Station is complete.
12. The NASA/Italian Space Agency agreement that a joint decision will be made in December 1994 on Italian Space Agency's provision of a Mini-Lab shall be considered in the assessment of each option.

REPORT DOCUMENTATION PAGE

Form Approved
OMB No. 0704-0188

Public reporting burden for this collection of information is estimated to average 1 hour per response, including the time for reviewing instructions, searching existing data sources, gathering and maintaining the data needed, and completing and reviewing the collection of information. Send comments regarding this burden estimate or any other aspect of this collection of information, including suggestions for reducing this burden, to Washington Headquarters Services, Directorate for Information Operations and Reports, 1215 Jefferson Davis Highway, Suite 1204, Arlington, VA 22202-4302, and to the Office of Management and Budget, Paperwork Reduction Project (0704-0188), Washington, DC 20503.

1. AGENCY USE ONLY (Leave blank)	2. REPORT DATE June 1993	3. REPORT TYPE AND DATES COVERED Technical Memorandum	
4. TITLE AND SUBTITLE Space Station Redesign Option A- Modular Buildup Concept		5. FUNDING NUMBERS	
6. AUTHOR(S) Compiled by Station Redesign Support Team Marshall Space Flight Center, AL 35812		8. PERFORMING ORGANIZATION REPORT NUMBER	
7. PERFORMING ORGANIZATION NAME(S) AND ADDRESS(ES) George C. Marshall Space Flight Center Marshall Space Flight Center, Alabama 35812		10. SPONSORING/MONITORING AGENCY REPORT NUMBER NASA TM-108415	
9. SPONSORING/MONITORING AGENCY NAME(S) AND ADDRESS(ES) National Aeronautics and Space Administration Washington, DC 20546		11. SUPPLEMENTARY NOTES	
12a. DISTRIBUTION/AVAILABILITY STATEMENT Unclassified-Unlimited		12b. DISTRIBUTION CODE	
13. ABSTRACT (Maximum 200 words) In early 1993, President Clinton mandated that NASA look at lower cost alternatives to Space Station Freedom. He also established an independent advisory committee-the Blue Ribbon Panel-to reweiv the redesign work and evaluate alternatives. Daniel Goldin, NASA Administrator, established a Station Redesign Team that began operating in late March from Crystal City, Virginia. NASA intercenter teams-one each at Marshall Space Flight Center, Johnson Space Center, and Langley Research Center-provided engineering and other support. This report summarizes the results of the Option A study done at Marshall Space Flight Center. Two configurations (A-1 and A-2) are covered in this report. Additional data is provided in the briefing package MSFC SRT-001, Final System Review to SRT-002, Space Station Option A Modular Buildup Concept, Volumes 1-5, Revision B, June 10, 1993. In June 1993, President Clinton decided to proceed with a modular concept consistent with Option A, and asked NASA to provide an Implementation Plan by September. All data from the Option A redesign activity was provided to NASA's Transition Team for use in developing the Implementation Plan.			
14. SUBJECT TERMS Space Station, Space Station Redesign, Modular Buildup Station, Space Station Option A		15. NUMBER OF PAGES 85	
		16. PRICE CODE NTIS	
17. SECURITY CLASSIFICATION OF REPORT Unclassified	18. SECURITY CLASSIFICATION OF THIS PAGE Unclassified	19. SECURITY CLASSIFICATION OF ABSTRACT Unclassified	20. LIMITATION OF ABSTRACT Unlimited